



IFS-2600
Fire Indicator Panel
TECHNICAL, PROGRAMMING
& INSTALLATION MANUAL

Installation Precautions

Adherence to the following will aid in problem-free installation with long-term reliability:

WARNING - Several different sources of power can be connected to the fire alarm control panel. Disconnect all sources of power before servicing. Control unit and associated equipment may be damaged by removing and/or inserting cards, modules, or interconnecting cables while the unit is energized. Do not attempt to install, service, or operate this unit until manuals are read and understood.

Verify that wire sizes are adequate for all initiating and indicating device loops. Most devices cannot tolerate more than a 10% I.R. drop from the specified device voltage.

Like all solid state electronic devices, this system may operate erratically or can be damaged when subjected to lightning induced transients. Although no system is completely immune from lightning transients and interference, proper grounding will reduce susceptibility. Overhead or outside aerial wiring is not recommended, due to an increased susceptibility to nearby lightning strikes. Consult with the Technical Services Department if any problems are anticipated or encountered.

Disconnect AC power and batteries prior to removing or inserting circuit boards. Failure to do so can damage circuits.

Remove all electronic assemblies prior to any drilling, filing, reaming, or punching of the enclosure. When possible, make all cable entries from the sides or rear. Before making modifications, verify that they will not interfere with battery, transformer, or printed circuit board location.

Do not over tighten screw terminals. Over tightening may damage threads, resulting in reduced terminal contact pressure and difficulty with screw terminal removal.

This system contains static-sensitive components. Always ground yourself with a proper wrist strap before handling any circuits so that static charges are removed from the body. Use static suppressive packaging to protect electronic assemblies removed from the unit.

Follow the instructions in the installation, operating, and programming manuals. These instructions must be followed to avoid damage to the control panel and associated equipment. FACP operation and reliability depend upon proper installation.

This equipment must be correctly programmed and installed to suit the specific application. Please ensure correct operational parameters are set prior to commissioning. If further details on programming options are required, please consult the programming manual or contact our helpful technical support personnel.

EMC WARNING:

This equipment may radiate radio frequency energy. It may also be affected by radio frequency energy and, if not installed and operated in accordance with the manufacturers instructions, may cause interference to radio communications. It has been tested and found to comply with the Class A radiated and conducted EMI requirements of AS/NZ 3548:1995 (including Amendments 1 & 2) as well as the EMI susceptibility requirements of Clause C3.5 in AS4428.0:1997.

Radio communication devices should not be used in the vicinity of fire panels or associated ancillary devices and systems.

Documentation Feedback

Your feedback helps us keep our documentation up to date and accurate. If you have any comments or suggestions about our printed manuals you can email us.

Please include the following information:

- Product name and version number (if applicable)
- Manual part number and revision (found on the front cover)
- Page number
- Brief description of the content you think should be improved or corrected
- Your suggestion for how to correct/improve documentation

Send email messages to:

techpubs@notifier.com.au

Please note this email address is for documentation feedback only. If you have any technical issues, please contact you nearest branch for technical support.

TABLE OF CONTENTS

COMPATIBLE DETECTORS.....	5
OVERVIEW.....	6
CAUTION	6
SPECIFICATION.....	7
APPROVALS.....	7
ENVIRONMENTAL LIMITS.....	7
POWER SUPPLY RATINGS AND SETTINGS	9
INTERNAL 24 VDC (nom) 3.0A MAIN POWER SUPPLY	9
INTERNAL 27.3V DC 1.5A BATTERY CHARGER.....	9
Internal 5VDC 2A Power Supply	9
EXTERNAL 27VDC POWER SUPPLY	10
BATTERY TYPE AND CAPACITIES	10
TECHNICAL DESCRIPTION	11
GENERAL	11
TRANSIENT SUPPRESSION.....	11
CURRENT CONSUMPTION	11
AZF DESCRIPTION.....	12
AZF SUPERVISORY CURRENT	12
OVERLOAD PROTECTION.....	12
ZONE OVERLOAD SELF RESET	12
PRINTER OUTPUT.....	13
CABLE CONNECTION	13
PROGRAMMING BY COMPUTER.....	13
ALIGNMENT AND ADJUSTMENT	14
PCB2006 POWER SUPPLY BOARD	14
INTERNAL 24VDC (nom) POWER SUPPLY.....	14
INTERNAL 27.3 VDC BATTERY CHARGER.....	14
EXTERNAL 24VDC (nom) POWER SUPPLY (if fitted)	14

PCB2005 TERMINATION BOARD..... 14
INTERNAL 5VDC POWER SUPPLY TP8..... 14
POWER SUPPLY COMPARATOR REFERENCE VOLTAGE TP10 14

NON ADJUSTABLE TEST POINTS..... 14

ALARM THRESHOLD COMPARATOR TP7..... 15

FAULT THRESHOLD COMPARATOR TP6 15

CONFIGURATION JUMPERS 16
IFS2004 - JP3 DEFAULT 16
IFS2004 - JP4 PROGRAM DISABLE 16
IFS2004 - JP5 CPU RESET..... 16
IFS2005 – JP2 DOOR HOLDER BYPASS..... 16
IFS2006 – JP1 EXTERNAL PS MONITORING..... 16
IFS804 - JP1-7 ZONE BOARD ADDRESSING..... 16

PLACING INTO OPERATION 17

EQUIPMENT AS FITTED 17

INITIAL CHECKLIST 17

POWER UP CHECKLIST..... 18

FUNCTIONAL TESTING 18

FAULT RECORD..... 19

INSTRUCTIONS TO OPERATORS..... 20

INDICATORS..... 20

SUGGESTED ALARM PROCEDURE 21

OPERATOR INSTRUCTIONS..... 21
FIREFIGHTER FUNCTIONS..... 21
GLOBAL FUNCTIONS 22
ZONE FUNCTIONS..... 24

PROGRAMMING..... 27

GLOBAL OPTIONS..... 27

ZONE OPTIONS 27

OUTPUT RELAY OPTIONS 28

DEFAULT SETTINGS..... 28

PROGRAM MODE..... 29
PROGRAMMING MODE..... 29
PROGRAMMING HIERARCHY 29
ZONES..... 29
RELAYS 30
GLOBAL 30
PRINT..... 30

MAIN MENU **30**
 EXIT PROGRAMMING MODE 31

ZONE PROGRAMMING..... **31**
 SELECT ZONE # 31
 ZONE SELECTED 31
 ZONE TYPE 31
 ZONE OUTPUT CONFIGURATION 32

RELAY PROGRAMMING MODE..... **32**
 SELECT RELAY # 32
 RELAY SELECTED 32
 RELAY TYPE 33
 RELAY MAPPING 33

GLOBAL PROGRAMMING **33**
 ACF OUTPUT 34
 AVF 34
 RELAY (GLOBAL RELAY UNITY MAP) 34

PRINT PROGRAMMING DATA **35**

TIME (DATE & TIME) **35**

APPENDIX A **36**

DESCRIPTION OF ALARM ZONE TYPES **36**
 LATCHING TYPE 36
 NON LATCHING TYPE 36
 TIME DELAY AZF 37

APPENDIX B **38**

ZONE OUTPUT CONFIGURATIONS..... **38**

APPENDIX C **39**

ALARM VERIFICATION FACILITY (AVF) **39**
 GLOBAL PROGRAMMABLE OPTIONS 39

APPENDIX D **40**

ANCILLARY TRIP (ACF)..... **40**
 GLOBAL PROGRAMMABLE OPTIONS 40

APPENDIX E..... **41**

RELAY OUTPUT MAPPING..... **41**

AND MAPPING **41**

OR MAPPING **41**

FAULT MAPPING..... **41**

FAULT/ISOLATE MAPPING **42**

ISOLATE MAPPING **42**

APPENDIX F	43
GLOSSARY OF TERMS.....	43
APPENDIX G.....	44
SUMMARY OF TERMINATIONS AND CAUTIONS.....	44
MCP LOOP.....	44
DETECTION ZONES	44
RELAY OUTPUTS	44
BELL OUTPUTS	44
ACF OUTPUTS.....	44
WARNING SYSTEM.....	44
DOOR HOLDER OUTPUTS	44
AUXILIARY POWER & MIMIC POWER	44
MAF ISOL & TRANSPONDER 0V	44
MIMIC DATA & CLOCK.....	44
AC INPUT	44
BATTERY	45
DOOR HOLDER AC INPUT	45
OUTPUT RELAYS	45
APPENDIX H	46
IFS-2600 PROGRAMMED OPTIONS.....	46
APPENDIX I.....	53
TECHNICAL DRAWINGS	53
MAIN KEYPAD AND DISPLAY.....	53
EXPANSION DISPLAY	53
Block Connection Diagram.....	54
System Sensor Conventional Detector Connection Diagram	54
System Sensor Conventional Detector Connection Diagram	55
Hochiki Conventional Detector Connection Diagram.....	55
Hochiki Conventional Detector Connection Diagram.....	56
Ancillary Connection Diagram.....	57
ASE Connection Diagram.....	58
Auto Changeover Dual Sounder Connection Diagram.....	59
Auto Change Over Dual Sounder Connection Diagram.....	60
MIMIC Connection Diagram.....	61
Single Fan Connection Diagram	62
Dual Fan Connection Diagram.....	63
Exhaust Fan Connection Diagram.....	64
Supply Fan Connection Diagram	65
Smoke Spill Fan Connection Diagram	66
10W EVAC Connection Diagram.....	67
10W EVAC Slave Connection Diagram.....	68
30W EVAC Connection Diagram.....	69
30W EVAC Slave Connection Diagram.....	70
50W EVAC Connection Diagram.....	71
50W EVAC Slave Connection Diagram.....	72

COMPATIBLE DETECTORS

Make	Model	Type	Model Number
System Sensor	Thermal	Type A	5451 AUS
System Sensor	Thermal	Type A	51A51
System Sensor	Thermal	Type B	4451 AUS
System Sensor	Thermal	Type B	51B51
System Sensor	Thermal	Type B Sealed	51B51S
System Sensor	Thermal	Type C	51C51
System Sensor	Thermal	Type D	51D51
System Sensor	Smoke	Photo-Optical	2151 AUS
System Sensor	Smoke	Photo-Optical	2151B AUS
System Sensor	Smoke	Ionisation	1151 AUS
System Sensor	Thermal	Type D	51D51
System Sensor	Smoke	Beam	BEAM1224
System Sensor	Smoke	Duct	DHP-100
Apollo	Thermal	Type A	Series 60
Apollo	Thermal	Type B	Series 60
Apollo	Thermal	Type C	Series 60
Apollo	Thermal	Type D	Series 60
Apollo	Smoke	Ionisation	Series 60
Apollo	Smoke	Photo Optical	Series 60
Hochiki	Thermal	Type A	DCA-B-60R MkV
Hochiki	Thermal	Type A	DCC-A
Hochiki	Thermal	Type A	DCD-A
Hochiki	Thermal	Type B	DFE-60B
Hochiki	Thermal	Type B	DFJ-60B
Hochiki	Thermal	Type C	DCA-B-90R Mk1
Hochiki	Thermal	Type C	DCC-C
Hochiki	Thermal	Type C	DCD-C
Hochiki	Thermal	Type D	DFE-90D
Hochiki	Thermal	Type D	FDJ-90D
Hochiki	Thermal Cool Room	Type B sealed	DFG-60BLKJ
Hochiki	Smoke	Ionisation	SIH-AM
Hochiki	Smoke	Ionisation	SIJ-ASN
Hochiki	Smoke	Photo Optical	SLK-A
Hochiki	Smoke	Photo Optical	SLR-AS
Olsen	Thermal	Type A	T56B-T6A
Olsen	Thermal	Type B	T56B-T6B
Olsen	Thermal	Type C	T56B-T6C
Olsen	Thermal	Type D	T56B-T6D
Olsen	Smoke	Ionisation	C24B
Olsen	Smoke	Photo Optical	P24B
Panelect	Thermal	Type A	PFS-A
Panelect	Thermal	Type B	PFS-B
Panelect	Thermal	Type C	PFS-C
Panelect	Thermal	Type D	PFS-D
Panelect	Smoke	Ionisation	PFS-I
Panelect	Smoke	Ionisation	PFS-I , MkII
Panelect	Smoke	Photo Optical	PFS-P
Panelect	Smoke	Photo Optical	PFS-P, MkII
IEI	VESDA E700, E70D	CONTACT DEVICE	

Please contact NOTIFIER INERTIA for any additional detectors.

OVERVIEW

IFS-2600 Fire Indicator Panel (FIP) is designed to provide simplicity to the end user. The FIP uses both a liquid crystal display and conventional LED displays for fast and accurate display of system status and changing events.

A custom designed membrane keypad is used together with the liquid crystal display and LED indicators to provide fast, efficient and simple modes of operation. The keypad also provides the required flexibility for the programming of the many user configurable options of this FIP. The FIP can be configured on-site without the need of expensive programmers or components.

A serial printer can also be connected if required. The printer can be used to output programming information for ease of modification, for safekeeping and to assist in the commissioning of the installation.

IFS-2600 uses serial chain mimic outputs which significantly saves time and costs of cabling to mimic panels.

A door holder power supply (using optional transformer) is incorporated into the system for the release of smoke and fire doors on alarm.

IFS-2600 is available in a standard 8-zone configuration and can be expandable to its fully expanded state as required. The IFS-2600 in its fully expanded state can;

- Monitor 64 detection zones
- Control 64 optional "mapped" relay outputs
- Output to a serial printer
- Output serially to a mimic panel
- Control to door holders
- Interface as required to any Australian Fire Brigade

IFS-2600 has been designed to be functional, flexible and reliable whilst maintaining a user-friendly interface.

CAUTION

IFS-2600 FIP has been tested and approved to AS4428.1 and meets the requirements of AS1670 and AS1668 Parts 1 & 2.

However, the equipment must be correctly programmed and installed to suit the specific application. Please ensure correct operational parameters are set prior to commissioning. If further details on programming options are required, please consult the programming manual or contact our helpful technical support personnel.

WARNING:

This equipment may radiate radio frequency energy. It may also be affected by radio frequency energy and, if not installed and operated in accordance with the manufacturers instructions, may cause interference to radio communications. It has been tested and found to comply with the Class A radiated and conducted EMI requirements of AS/NZ 3548:1995 (including Amendments 1 & 2) as well as the EMI susceptibility requirements of Clause C3.5 in AS4428.0:1997

CAUTION: Radio communication devices should not be used in the vicinity of fire panels or associated ancillary devices and systems

SPECIFICATION

Cabinet	Zinc Sealed Steel 1.6mm
	Powder Coated
	Hinged Inner Door
	Hinged Outer Door
Outside Dimensions	2608 (8 zones) 394mm H x 390mm W x 180mm D* 2624 (24 zones) 750mm H x 390mm W x 180mm D* 2600 (32 to 64 zones) 18U, 28U & 40U Cabinets Battery Box *Note: the depth quoted is including the door and break glass. The internal cabinet depth not including the door and break glass is 140mm.
AC Operational Voltage	240 VAC 50Hz ± 10%
Internal Power Supplies	Battery Charger 27.3 VDC 1.5AMP
	Panel Supply 24 VDC (nom) 3.0AMP
	Logic Supply 5 VDC 2.0AMP
Microprocessor	80C52
Memory Type	Non-volatile E ² ROM
Liquid Crystal Display	2 Lines x 16 Characters LED Backlit
Fuses	F1: Panel Supply M205 5A
	F2: Battery Charger M205 3A F3: Battery Protection Polyfuse 3A F4: External Supply M205 7A F5: Door Holder M205 3A F6: Aux Power Output M205 1A Slow Blow F7: Bell M205 1A F8: Warning System M205 1A F9: ACF M205 1A
E.O.L Resistor On AZFs, monitored outputs, Bells, Warning system, ACF	4K7 Ohms

APPROVALS

Australian Standard AS4428.1 1998

SSL Approval No AFP-1553

C-Tick Approval No. N1336

ENVIRONMENTAL LIMITS

-10 Deg. C to +55 Deg. C Dry heat.
+40 Deg. C @ 93% Relative Humidity.

SYSTEM EXPANSION

Zones	Qty	Hardware Required	Product Code
8	1	Main Control Board	PCB-2004
	1	Main Termination board	PCB-2005
	1	Power Supply board	PCB-2006
16	1	Main Control board	PCB-2004
	1	Main Termination board	PCB-2005
	1	Power Supply board	PCB-2006
	1	8 Zone Expansion board	PCB-804G3
	1	16 Zone Indicator board	PCB-816
24	1	Main Control board	PCB-2004
	1	Main Termination board	PCB-2005
	1	Power Supply board	PCB-2006
	2	8 Zone Expansion board	PCB-804G3
	1	16 Zone Indicator board	PCB-816
32	1	Main Control board	PCB-2004
	1	Main Termination board	PCB-2005
	1	Power Supply board	PCB-2006
	3	8 Zone Expansion board	PCB-804G3
	2	16 Zone Indicator board	PCB-816
40	1	Main Control board	PCB-2004
	1	Main Termination board	PCB-2005
	1	Power Supply board	PCB-2006
	4	8 Zone Expansion board	PCB-804G3
	2	16 Zone Indicator board	PCB-816
48	1	Main Control board	PCB-2004
	1	Main Termination board	PCB-2005
	1	Power Supply board	PCB-2006
	5	8 Zone Expansion board	PCB-804G3
	3	16 Zone Indicator board	PCB-816
56	1	Main Control board	PCB-2004
	1	Main Termination board	PCB-2005
	1	Power Supply board	PCB-2006
	6	8 Zone Expansion board	PCB-804G3
	3	16 Zone Indicator board	PCB-816
64	1	Main Control board	PCB-2004
	1	Main Termination board	PCB-2005
	1	Power Supply board	PCB-2006
	7	8 Zone Expansion board	PCB-804G3
	4	16 Zone Indicator board	PCB-816

Additional relay outputs:

Relays	Qty	Hardware Required	Product Code
8	1	Relay board containing 8 relays 24VDC 1A	IFS-717
16	2	Relay board containing 8 relays 24VDC 1A	IFS-717
24	3	Relay board containing 8 relays 24VDC 1A	IFS-717
32	4	Relay board containing 8 relays 24VDC 1A	IFS-717
40	5	Relay board containing 8 relays 24VDC 1A	IFS-717
48	6	Relay board containing 8 relays 24VDC 1A	IFS-717
56	7	Relay board containing 8 relays 24VDC 1A	IFS-717
64	8	Relay board containing 8 relays 24VDC 1A	IFS-717

POWER SUPPLY RATINGS AND SETTINGS

INTERNAL 24 VDC (nom) 3.0A MAIN POWER SUPPLY

This supply's primary function is to power panel logic and all external operations of the FIP, i.e.: detection circuits, ancillary circuits, etc. This supply meets the requirements of AS4428.5.

AC Input	30 VAC +10% - 15%
Output Current	3.0 AMPS
Output Voltage	26.5 VDC
Current Limit	3.0 AMPS
Output Ripple	50 mV

INTERNAL 27.3V DC 1.5A BATTERY CHARGER

Its primary function is to charge the batteries. This supply meets the requirements of AS4428.5.

AC Input	30 VAC +10% -15%
Output Current	1.5 AMPS
Output Voltage	27.3 VDC
Current Limit	1.5 AMPS
Output Ripple	200 mV

Important Note:

After a power failure, the battery will only reconnect to the charger if the battery voltage is above approximately 20V +/- 2V.

A battery fault will be generated in the event that the battery does not automatically reconnect. This is to ensure that a faulty or dead flat battery (due to an extended power failure) does not bring the entire system down.

In order to reconnect a flat battery, it is necessary to disconnect the battery from the panel and charge it externally. The battery should be thoroughly tested before returning it to service.

In the event that an external charger is not available, the battery may be trickle charged above 22V via a 30 ohm, 5W resistor connected between the 24v Aux Output and the battery positive terminal. A 1N4004 Diode (Notifier part number #286) or similar should also be fitted in series with the resistor to stop the battery from pulling down the main panel voltage. Trickle charging the battery by this method may take several hours to bring it up to the minimum level.

The battery can then be reconnected to the panel for charging via the internal battery charger. It is important that the voltage on the battery be monitored to ensure that it is charging. The battery should then be left for 24 hours and then fully tested to ensure that no damage has occurred due to the deep discharge.

Internal 5VDC 2A Power Supply

This supply's primary function is to power all internal operations of the FIP, i.e.: Microprocessor, liquid crystal display, LED's keypad etc.

AC Input	30 VAC +15% or 27.6VDC+15%
Output Current	2.0 AMPS
Output Voltage	5.0 VDC
Current Limit	2.0 AMPS
Output Ripple	150 mV

EXTERNAL 27VDC POWER SUPPLY

This supply is used in addition to the internal power supply for large systems. Its primary function is to power any additional ancillary loads of the FIP up to 7 amps. This supply meets the requirements of AS4428.5

Important Notes:

When using external power supply, JP1 link on IFS2006E must be fitted to enable external PSU monitoring.

If this supply is used to power a NI-2008 gas module, the following additional components are required to ensure a break free change over from the mains supply to the panel battery in case of mains fail condition.

1. A 6A4 or P600G rectifier diode (Notifier part number #266) is to be installed in series with the external +27V output of the IFS-2600 termination board.

2. A 3300µF 50V Electrolytic Capacitor (Notifier part number #1248) should be installed across the +27V and 0V of the ancillary device.

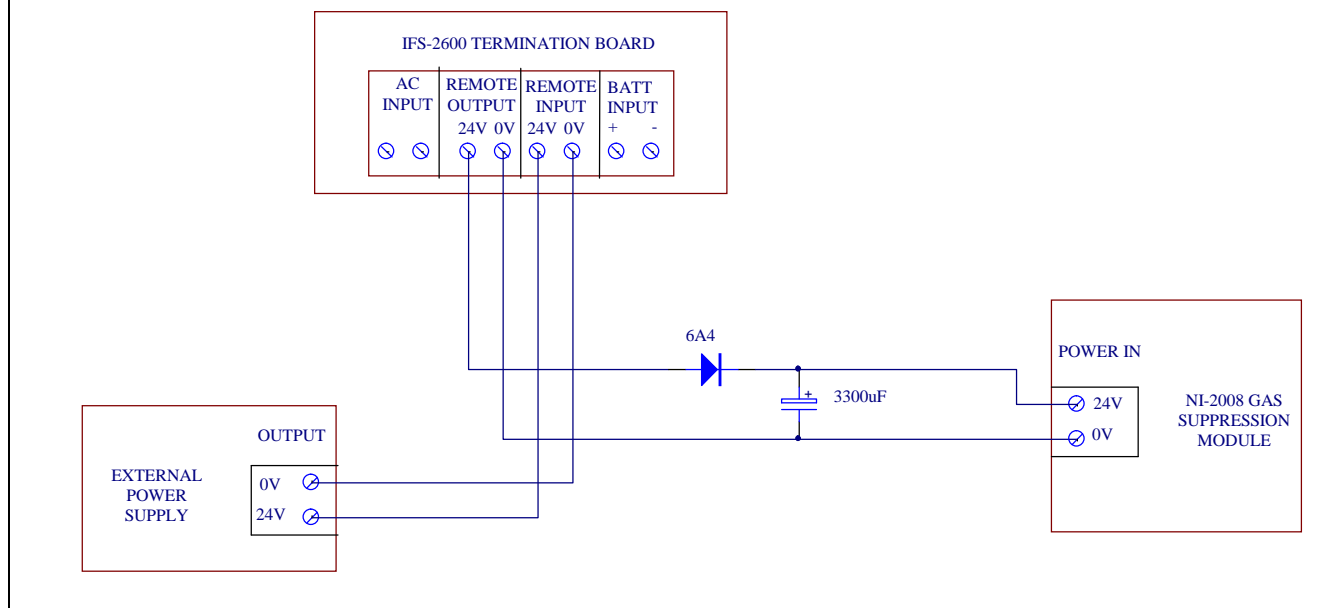

BATTERY TYPE AND CAPACITIES

In general, any Sealed Lead Acid Battery, or Wet Lead Acid Battery designed for stationary use is compatible with the IFS-2600 Fire Indicator Panel. Automotive batteries must not be used. The use of Nickel Cadmium batteries is not recommended.

Manufacturer	Type	Number	Voltage	Capacity (Ah)	Qty Required
Best and Best	Sealed LA	BP17-12	12	17	2
Best and Best	Sealed LA	BP24-12	12	24	2
Best and Best	Sealed LA	BP40-12	12	40	2
Olympic Batteries	Sealed LA	CJ12-7	12	7	2
Olympic Batteries	Sealed LA	CJ12-12	12	12	2
Olympic Batteries	Sealed LA	CJ12-18	12	18	2
Olympic Batteries	Sealed LA	CJ12-26	12	26	2
Olympic Batteries	Sealed LA	CJ12-33	12	33	2
Olympic Batteries	Sealed LA	CJ12-40	12	40	2
Olympic Batteries	Sealed LA	CJ12-88	12	88	2
Olympic Batteries	Sealed LA	CJ12-100	12	100	2

TECHNICAL DESCRIPTION

GENERAL

The IFS-2600 in its most basic form comprises of three boards, the main control board, the main termination board and the power supply board.

The main control board contains the Microprocessor, EPROM, RAM and E²ROM. The main control board also has the liquid crystal display and keypad attached. All of the "delicate" electronics have been placed on this board. The main control board complete with the inner door is easily removed during installation to avoid damage and allow greater access to the field terminals.

The main termination board contains the one power supply for 5V logic, and connectors for a Power Supply and Battery Charger daughter board, the first eight zones, all common outputs and the printer interface. All charger settings, fuses etc are located on this board. The Power Supply and Battery Charger board contains two switch mode regulators, 26.5V for the panel power, 27.3V for the battery charger.

Up to seven (7) zone expansion boards can be added to the system to increase its detection capability. These boards contain the same electronics as on the main termination board for zone scanning. Addressing is by a jumper that selects which group of eight zones the board refers to.

Up to four (4) zone indicator boards can also be added. These boards will display the status of the zone expansion boards fitted.

Up to eight (8) relay boards can be added. These boards contain 8 change-over relay contacts, each rated at 1 amp. These boards require no addressing, as they work on a serial data chain. Output 1 is the closest output to the main board.

NOTE This product utilises state of the art components and materials and therefore boards must be returned to our factory for proper troubleshooting, repair and retesting. Field component level repairs are not recommended and would void all warranties on the product.

TRANSIENT SUPPRESSION

The IFS-2600's superior transient protection comprises of Dual Transorb input traps, inductive paths on incoming PCB tracks, circuit board planes and metal oxide varistors on outputs. These devices are all self-resetting.

CURRENT CONSUMPTION

Zones Fitted	Quiescent Current	Quiescent + 2 AZF'S in alarm +1A of Bell +1 Amp ACF
8	150 mA	2.23 AMPS
16	250 mA	2.33 AMPS
24	350 mA	2.43 AMPS
32	450 mA	2.53 AMPS
40	550 mA	2.63 AMPS
48	650 mA	2.73 AMPS
56	750 mA	2.83 AMPS
64	850 mA	2.93 AMPS

Note:

- 1: Each installation would require individual battery calculations to be performed for load capacity and power supply capacity.
- 2: Each IFS-717 relay board, can add 370 mA (in alarm and quiescent) current per board.

AZF DESCRIPTION

The AZF's on the IFS-2600 are monitored and scanned by custom thick film hybrids. These hybrid IC's significantly reduce the possibility of false alarms and improve product efficiency and reliability.

The total Alarm Zone loop resistance is the sum of the end of line resistor (EOLR 4K7) plus all the parallel connected detector loads.

AZF SUPERVISORY CURRENT

The supervisory current flows through the external terminal AZF+, through the field cable and to the end of line resistor (EOLR), returning to the panel at AZF- terminal. Parallel connected, across the 2-wire pair field cable, are a number of the previously listed detectors. During the quiescent state there is essentially an open circuit across the + and - terminals of the detector base. The maximum number of detectors that can be installed on each AZF is dependant on the type of detector and is listed in the IFS-2600 **ActivFire**® listing.

In an alarm state, a 560-ohm resistor is connected across the detector base causing additional loop current to flow. This is sensed by the AZF to produce an alarm output. Removal of the E.O.L. resistor (in a non alarm state) or the interruption of the supervisory current will produce a fault signal in the AZF.

As described above, the level of current is used to define the status of the alarm zone: -

I = 3.5 mA and below	FAULT
I = 4.0 - 5.0mA at 24V	QUIESCENT
I = 16 mA to 40 mA (current limited)	ALARM

The zone current is used by the hybrid IC to determine the condition of the zone as above. This information is then transferred to the microprocessor for processing.

OVERLOAD PROTECTION

Panel Supply	Fuse F1	M205 5A
Battery Charger	Fuse F2	M205 3A
Battery Protection	Fuse F3	Polyfuse 3A
External Supply	Fuse F4	M205 7A
Door Holder	Fuse F5	M205 3A
Aux Power Output	Fuse F6	M205 1A Slow Blow
Bell	Fuse F7	M205 1A
Warning System	Fuse F8	M205 1A
ACF	Fuse F9	M205 1A
AZF Circuits	Current Limited	40mA

ZONE OVERLOAD SELF RESET

If a zone is overloaded by an accidental short to earth on an AZF circuit, the zone will automatically shut down and produce a fault. Once this happens the panel will automatically recheck the zone every 60 seconds and once the overload is removed, restore power and the fault will clear.

PRINTER OUTPUT

The printer port is designed to be used during testing and commissioning of the panel. The serial printer will report alarms and faults together with the date and time of the event. The printer can also be used during "walk test" mode to produce a history of the test and can also be used to print current programming configuration.

A DB9 plug male is provided at the top of the main termination board. This communication port will communicate with an IBM compatible serial printer (ASCII printer) with the following settings.

Baud Rate	1200 bps
Data Bits	8
Stop Bits	1
Parity	None
Handshaking	DTR

CABLE CONNECTION

Cabling to the printer requires a 4-core telephone style cable with a maximum length of 10 metres. A DB9 socket is required at the panel end. The printer end is dependent on the type of printer used but is usually a male DB25. Connection is as follows. A 5-core cable can be used for both comms and printer functions

IFS-2600 END		PRINTER END	
DB9 FEMALE		DB25 MALE	DB9 MALE
2	RX (only for programming)	2	3
3	TX	3	2
5	GND	7	5
7	RTS (do not use)	(5)	(8)
8	CTS (only for printer)	4	7

PROGRAMMING BY COMPUTER

Programming of the zones, relays, global functions and time can be set with the DOS based program "2600/SW" using the printer port. (Cannot be used with Windows XP)

After the cable is installed, the program can be run and the menu will prompt for the available functions.

```

INERTIA- 2600  CONFIGURATION MENU
=====
D - SET TO FACTORY DEFAULT
F - FILE, UPLOAD, DOWNLOAD MENU
G - GLOBAL CONFIGURATION
V - VIEW CURRENT CONFIGURATION
Z - ZONE CONFIGURATION
R - RELAY CONFIGURATION
X - EXIT TO SYSTEM
PLEASE SELECT FUNCTION

```

ALIGNMENT AND ADJUSTMENT

PCB2006 POWER SUPPLY BOARD

INTERNAL 24VDC (nom) POWER SUPPLY

With batteries disconnected and no alarms present, measure voltage across the 0V and MAIN test points on the 2006 power supply board and, if necessary, adjust the multi-turn potentiometer VR2 until voltage is $26.5V \pm 0.05V$ (26.45V – 26.55V).

Current limiting is fixed and field adjustment is not possible.

INTERNAL 27.3 VDC BATTERY CHARGER

With batteries disconnected and no alarms present, measure voltage across the 0V and CHARG test points on the 2006 power supply board and, if necessary, adjust the multi-turn potentiometer VR1 until voltage is $27.3V \pm 0.05V$ (27.25V – 27.35V).

Current limiting is factory preset and field adjustment is not required.

EXTERNAL 24VDC (nom) POWER SUPPLY (if fitted)

With batteries disconnected and no alarms present, measure voltage across Remote Input terminals on PCB2005 and adjust the voltage on the external power supply until the voltage is $26.5V \pm 0.5V$ (26.0V – 27.0V). Note: This voltage is not critical for the operation of the IFS-2600 panel, but the voltage must not go outside the limits as specified for the field ancillaries that it powers.

PCB2005 TERMINATION BOARD

INTERNAL 5VDC POWER SUPPLY TP8

All parameters are fixed and field adjustment is not possible.

POWER SUPPLY COMPARATOR REFERENCE VOLTAGE TP10

With the panel in the quiescent mode, measure voltage between system 0V and TP10. Adjust multi-turn potentiometer VR3 until voltage is $7.0V \pm 1\%$ (6.93V – 7.07V)

NON ADJUSTABLE TEST POINTS

TP8 = 5.0 VDC $\pm 5\%$ 5VDC POWER SUPPLY
TP5 = 12.0 VDC $\pm 5\%$ 12VDC POWER SUPPLY

(If these test point voltages are not correct, please return the main termination board to the factory for repair.)

ALARM THRESHOLD COMPARATOR TP7

With the panel in the quiescent mode, measure and take note of the INTERNAL 24V DC POWER SUPPLY as above.

Measure voltage between system 0V and TP7. Adjust multi-turn potentiometer VR4, and adjust until the voltage is as per the following table.

Rail Voltage	3.3V Setting	Range
20.6	2.833	2.80 to 2.86
21.0	2.888	2.86 to 2.92
21.5	2.956	2.93 to 2.99
22.0	3.025	2.99 to 3.06
22.5	3.094	3.06 to 3.12
23.0	3.163	3.13 to 3.19
23.5	3.231	3.20 to 3.26
24.0	3.300	3.27 to 3.33
24.5	3.369	3.34 to 3.40
25.0	3.438	3.40 to 3.47
25.5	3.506	3.47 to 3.54
26.0	3.575	3.54 to 3.61
26.5	3.644	3.61 to 3.68
27.0	3.713	3.68 to 3.75
27.5	3.781	3.74 to 3.82
27.6	3.795	3.76 to 3.83
28.0	3.850	3.81 to 3.89

FAULT THRESHOLD COMPARATOR TP6

With the panel in the quiescent mode, measure and take note of the INTERNAL 24V DC POWER SUPPLY as above.

Measure the voltage between system 0V and TP6. Adjust multi-turn potentiometer VR1, and adjust until the voltage is as per the following table.

Rail Voltage	0.6V Setting	Range
20.6	0.600	0.59 to 0.61
21.0	0.612	0.61 to 0.62
21.5	0.626	0.62 to 0.63
22.0	0.641	0.63 to 0.65
22.5	0.655	0.65 to 0.66
23.0	0.670	0.66 to 0.68
23.5	0.684	0.68 to 0.69
24.0	0.699	0.69 to 0.71
24.5	0.714	0.71 to 0.72
25.0	0.728	0.72 to 0.74
25.5	0.743	0.74 to 0.75
26.0	0.757	0.75 to 0.76
26.5	0.772	0.76 to 0.78
27.0	0.786	0.78 to 0.79
27.5	0.801	0.79 to 0.81
27.6	0.804	0.80 to 0.81
28.0	0.816	0.81 to 0.82

CONFIGURATION JUMPERS

IFS2004 - JP3 DEFAULT

Holding a short across these pins for 5 seconds during start-up causes the panel to reset to standard factory defaults. The panel will give 4 beeps after reset, to acknowledge default on start-up.

IFS2004 - JP4 PROGRAM DISABLE

When fitted, jumper between these pins to inhibit program changes.

IFS2004 - JP5 CPU RESET

With panel operating, a momentary short across these pins will cause a CPU restart.

IFS2005 – JP2 DOOR HOLDER BYPASS

If zoned door holder outputs are required and is to be done external to the main termination board, then the main door holder release needs to be disabled. Fitting a link across JP2 on IFS2005 PCB does this.

Note: Door holder output is only enabled if optional door holder transformer is fitted. SW1 must be linked on PCB2004 CPU board prior to Version 6 Firmware.

IFS2006 – JP1 EXTERNAL PS MONITORING

When using external power supply, JP1 link on IFS2006E must be fitted to enable external PSU monitoring.

IFS804 - JP1-7 ZONE BOARD ADDRESSING

Jumper JP1 to JP7 on zone expansion board IFS-804 selects the addressing for the zones. Place jumper in link position for the appropriate 8 zones to which the expansion board applies.

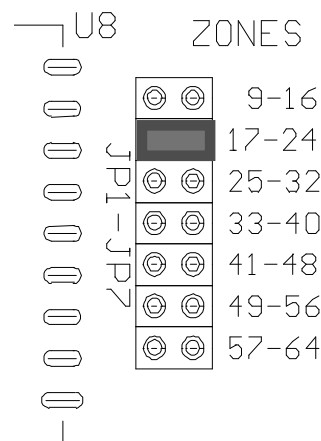
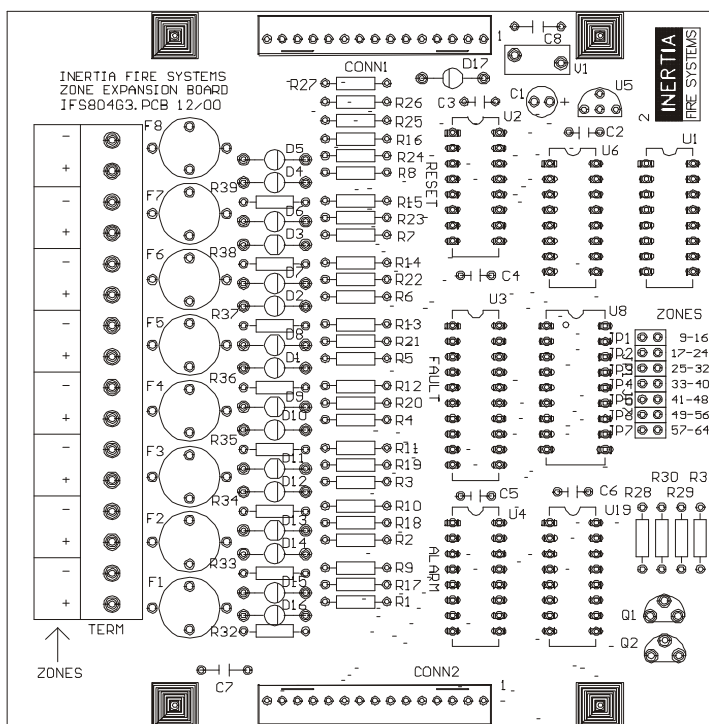

PLACING INTO OPERATION

Suitably qualified technicians must install the panel. The following check procedures are recommended after every installation and prior to initial power-up.

A thorough visual inspection should be made to every aspect of the fire panel. This includes loose wire, metal filings, loose circuit boards, loose cabling, damage in transit etc.

All problems must be rectified immediately as they could cause incorrect operation or permanent damage to the equipment.

EQUIPMENT AS FITTED

QTY	Description	Code
1	MAIN CONTROL BOARD	IFS -2004
1	MAIN TERMINATION BOARD	IFS -2005
1	MAIN POWER SUPPLY	IFS -2006
	8 ZONE EXPANSION BOARD	IFS -804
	16 ZONE INDICATOR BOARD	IFS -816
	ADD ON, 8 WAY RELAY BOARD	IFS-717
	EXTERNAL POWER SUPPLY BOOSTER	PS244, PS249, NPS-3, NPS-5, NPS-11
	3A DOOR HOLDER P/SUPPLY TRANSFORMER	2600/DHTX

INITIAL CHECKLIST

- System general appearance good
- Cabinet colour and condition good
- Cabinet keyed 003
- All circuit boards firmly fastened
- Manual call point fitted & functional
- Viewing window clear and firmly secured
- Cable entries adequately sealed
- 240VAC mains cabling is correctly terminated
- All earthing secured
- Transformer securely mounted
- Transformer correctly wired
- All ribbon cables firmly secured
- All operational zones adequately identified
- All fuses correct value and fitted properly
- All other modules securely fitted
- Manufacturing label affixed

You are now ready to power up the IFS-2600 Fire Indicator Panel.

POWER UP CHECKLIST

- Ensure batteries are disconnected.
- Turn mains switch to "on"
- The "mains on" led should light.
- Allow 15 seconds for the panel to perform its start up tests.
- Connect batteries

FUNCTIONAL TESTING

- Primary ac supply voltage: 200 or 220 or 240vac \pm 10% as required
- Charger output voltage without batteries: 27.3v dc
- Keypad functional
- Perform auto test

- Led's all functional
- LCD backlighting functional
- Liquid crystal display functional
- Zone fault detection
- Zone alarm detection

- Internal sounder operating
- MCP loop wired to zone number _____ (if applicable)
- Test auxiliary power output
- Test bell output
- Test warning system output
- Test ACF output
- Test door holder output (optional)
- Test bell output supervision
- Test warning system output supervision
- Test ACF output supervision
- Test brigade alarm relay #1
- Test brigade alarm relay #2
- Test standby relay (normally energised)
- Test fault relay (normally energised)
- Test mains fail relay
- Test isolate relay
- Test general alarm relays (2)
- Test relay boards (if fitted)
- Test open collector output boards (if fitted)
- Press "battery test" once
- If batteries are flat, allow 24hrs to charge and then re-test.

FAULT RECORD

FAULT	CORRECTION	DATE

TESTS SATISFACTORILY COMPLETED.

TESTED BY _____

SIGNATURE _____

DATE OF TEST _____

If all faults have been rectified and all tests are completed satisfactorily, the **2600** fire indicator panel is now ready for operation.

INSTRUCTIONS TO OPERATORS

INDICATORS

Qty	Descriptor	Colour	Function	Buzzer
1	MAINS ON	Green	Illuminates when there is 200/220/240 VAC supply to the panel.	
1	BATTERY FAULT	Yellow	Illuminates if the battery fails a battery test. Illuminates if batteries are disconnected >30 seconds. Illuminates if batteries are short circuit >30 seconds.	Yes
1	PSU FAULT	Yellow	Illuminates if the power supply is outside the manufacturers range.	Yes
1	CHARGER LOW	Yellow	Illuminates if the battery charger is outside the recommended float charge voltage.	Yes
1	COMMON FAULT	Yellow	Illuminates if; Any un-isolated zone goes into fault. ACF output is open or short circuit Bell output is open or short circuit Warning System output is open or short circuit Battery Fault Charger Fault Power Supply Fault MAF Isolate Input is Open Circuit Configuration Fault	Yes
1	ACF ACT	Red	Illuminates if the ACF output has been activated.	
1	ACF FLT	Yellow	Illuminates if the ancillary circuit is open or short circuit. The LED will extinguish when the load is restored.	Yes
1	ACF ISO	Yellow	Illuminates if the ancillary output has been manually isolated.	
1	Bell ACT	Red	Illuminates when the bell output has been energised.	
1	Bell FLT	Yellow	Illuminates if the bell circuit is open or short circuit. The LED will extinguish when the load is restored.	Yes
1	Bell ISO	Yellow	Illuminates if the bell output has been manually isolated.	
1	Warning System ACT	Red	Illuminates if the Warning System output has been energised.	
1	Warning System FLT	Yellow	Illuminates if the Warning System circuit is open or short circuit. The LED will extinguish if the load is restored.	Yes
1	Warning System ISO	Yellow	Illuminates if the Warning System has been manually isolated.	
8	ALARM LEDS	Red	This LED will flash if it's corresponding zone goes into alarm. It will remain flashing until it is Acknowledged at which time it will go steady and remain on until the alarm is reset. If the zone is programmed as a time delay type, a steady LED indicates the "pre-alarm" condition. If the zone is isolated and in alarm it will also be steady.	Yes
8	FAULT LEDS	Yellow	This LED illuminates if it's corresponding zone goes into fault. It will remain on until the fault is removed.	Yes
8	ISOLATE LEDS	Yellow	This LED illuminates if its corresponding zone is isolated. It will remain on until the zone is de-isolated.	

SUGGESTED ALARM PROCEDURE

The following is a suggested alarm procedure for use by building fire officers or duty wardens. The fire indicator panel is designed for use by qualified fire fighters and it is strongly recommended that the fire panel not be operated in an emergency situation by anyone other than suitably qualified fire fighters.

- Do not open fire indicator panel door or press any buttons until fire officers arrives.
- Determine location of the fire by inspecting the label beside any lit red zone alarm LEDs on the panel.
- Visually inspect area at a safe distance for actual fire or false alarm.
- Notify fire-monitoring station of either result.
- Perform evacuation and extinguishing operations as required.
- IF a FIRE, direct fire fighters to the fire indicator panel and cause of alarm as they arrive.
- IF a FALSE ALARM, advise maintenance technicians to determine and rectify cause.
- Record all events in logbook.

NOTE A suitably qualified fire officer should perform the above procedure. These are suggested procedures only, and if specific fire procedures are available or issued, they MUST prevail.

OPERATOR INSTRUCTIONS

The functions of the IFS-2600 are divided into three (3) categories

- Fire Fighter Functions
- Global Functions
- Zone Functions

FIREFIGHTER FUNCTIONS

Fire Fighter Functions are those specifically used by the Fire Brigade on attendance. Following is an explanation of their operation and the keystrokes required to perform the function required. These keys are located at the top of the keypad marked FIREFIGHTER'S FACILITY and bordered in red.

ACKNOWLEDGE

A rectangular button with a thick black border and the word "ACK" in bold, uppercase letters.

The purpose of the internal buzzer is to alert persons of a new event on the panel, and a new potential fire danger. Once the fire's location has been determined, the fire-fighter may wish to silence the internal buzzer without having to totally reset the alarm.

When the buzzer is operating, pressing the "ACK" key once will silence it, however the External Alarm Bell will continue to sound. If a subsequent alarm arises, the buzzer will be reactivated and a second ACK operation will be required to silence it.

When an alarm is acknowledged, the Alarm LED will stop flashing and light continuously.

RESET

A rectangular button with a thick black border and the word "RESET" in bold, uppercase letters.

The reset function momentarily disconnects power, and resets all alarm parameters for the zone(s) that have been acknowledged. This returns the zone back to its "normal" state. The reset key only operates on zones with acknowledged alarms.

ISOLATE

A rectangular button with a thick black border and the word "ISOLATE" in bold, uppercase letters.

The isolate function prevents the transmission of alarms or faults from the zones to the master alarm facility. The isolate key only operates on zones with acknowledged alarms.

BELL ISOLATE



Depressing the "EXT BELL ISOLATE" key will isolate the bells. The "Ext Bells Isolate" LED will illuminate and the bells will not sound until the bells are de-isolated. Pressing "EXT BELL ISOLATE" a second time will de-isolate the bell.

WARN SYS ISOLATE

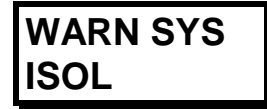

Depressing the "WARN SYS ISOLATE" key will isolate the warning system. The "Warn Sys Isolate" LED will illuminate and the warning system will not operate in the event of an alarm. Pressing "WARN SYS ISOLATE" a second time will de-isolate the warning system.

GLOBAL FUNCTIONS

Global functions are those relating to the overall system and are not specific to particular zones. Following is an explanation of their operation and the keystrokes required to perform the function.

BATTERY TEST



This function tests the performance of the batteries fitted to the system. Pressing this button will initiate a battery test as specified in AS4428. The test will temporarily disconnect the batteries from the panel and apply load on the batteries for 15 seconds.

The result of the test will be displayed on the LED's. If the "Battery Fault" LED is on, only a successful battery test will turn the LED off. The pressing of any key during the test period will abort the battery test and return the system back to normal mode.

Battery test function is disabled when the panel is in alarm condition.

AUTO TEST MODE



This function will perform a fixed automatic test procedure to the panel. This mode cannot be selected if any zone(s) is in alarm. Auto test will perform the following test functions;

- Turn on ALL LEDs for 0.5 seconds
- Test LCD backlighting
- Test panel memory (E²ROM & RAM)
- Test LCD
- Isolate all alarm zones
- Fault test all alarm zones
- Alarm test all alarm zones
- Test buzzer

The pressing of any key during "AUTO TEST" will abort the tests and return the system back to normal mode once the current test is complete.

Note During "AUTO TEST", all zones are treated as zone type #1 (standard latching type with 2 second delay). Once AUTO TEST has finished, all zones will be reset and returned back to their previously configured types.

WALK TEST MODE



This function will place the panel into "walk test" mode. Walk test mode is used for the on-site testing of detector zones. This mode cannot be selected if any zone(s) is in alarm. Entry to walk test mode will be acknowledged by three beeps and the LCD will display "WALK TEST MODE".

For the duration of walk test mode, all zones are changed to output configuration #2 (indicate and ring bells only) and all zones are set to type #1 (standard latching, 2 second).

If the bells are not required to ring during walk test, simply press the "EXT BELL ISOLATE" key once. The EXT BELL ISOLATE LED will illuminate to verify that the bells have been isolated.

Any alarm signal from detectors etc. will be received by the panel on its appropriate zone. The panel will beep to acknowledge receipt of the alarm and indicate the alarm by illuminating the appropriate alarm LED for 4 seconds (the bells will also ring for a 3 second period unless previously isolated).

The zone and detector will then be automatically reset for 15 seconds

If the optional printer is connected, the alarm will be printed out as it is received. This can eliminate the need for a second serviceman to record zone numbers during walk test and the printout can be retained for verification at a later date.

Pressing any key will terminate the walk test mode and return the panel back to normal operation, restoring all zone types and output configurations also ensuring that bell and ancillary outputs are de-isolated. The bells will give three pulses of 1 second each to warn any testers still in the building that walk test mode has been terminated.

Failure to receive any alarms or keystrokes within a 15 minutes period will result in the panel automatically exiting walk test mode and returning back to normal as follows:

- Bell outputs to be de-isolated.
- Ancillary outputs to be de-isolated.
- Bell will sound 3 times, each of 1-second duration.
- Exit from walk test mode.
- Zone types and output configurations restored

ACF ISOLATE



Depressing the "ACF ISOLATE" key will isolate the ACF (Ancillary output) and the Door Holder Output. The ACF isolated LED will illuminate and the output will not operate until de-isolated. Pressing "ACF ISOLATE" for a second time will de-isolate the output.

If the ancillary output has already been tripped and is programmed as latching, isolating the ACF will not affect the existing ancillary output. If the ACF is isolated prior to the alarm, it will prevent the ancillary output from tripping. This does not apply to the Door Holder output.

ACF RESET



Resetting of the ancillary output (ACF) is only required if the ancillary output was programmed as latching.

The ancillary alarm will remain latched until manually reset. Pressing the "ACF RESET" button will extinguish the 'ACF Activated' LED and de-energise the ancillary output. Pressing "ACF RESET" when the ACF is not tripped will have no effect.

ZONE FUNCTIONS

Zone functions are those relating specifically to the detection zones. Following is an explanation of their operation and the keystrokes required to perform the function required.

ALARM TEST

ALARM TEST**#****ENT**

The alarm test function momentarily disconnects the detector lines of the zone(s) under test and simulates a detector going into alarm, therefore testing the zone(s) alarm detection capability.

A resistive load equal to worst case alarm condition is placed on the zone for a period of 120 seconds and then removed, if the zone being tested is not a latching type, the alarm will reset automatically once the load is removed. Acknowledging and resetting the alarm will terminate an alarm test.

Once the zone has alarmed, all outputs are initiated (as programmed) similar to a real alarm.

The zone may be isolated prior to an alarm test if desired; this will prevent any outputs from operating.

'#' in the above key sequence is the zone number.

If only one zone is to be tested, use the appropriate number. Alternatively the "ALL" button can be used to simultaneously test all zones.

To perform an alarm test:

1. Press the "ALARM TEST" button once; the buzzer will give 2 short beeps to indicate that alarm test mode has been entered.
2. The LCD display will read "ALARM TEST MODE, ENTER ZONE No.".
3. Now enter the zone number ("#") 1-64 or "all"
4. Press "ENT"

If a correct entry is made, alarm testing on the zone commences immediately. However remember there is a 2 second transient delay on all zones. It will therefore take approximately 2 seconds before the zone registers an alarm (this could be longer, depending on zone type).

A long beep will signify an incorrect entry and will revert back to normal operating mode. The "ALARM TEST" button will need to be depressed again to re-enter alarm test mode.

FAULT TEST

FAULT TEST**#****ENTER**

The fault test function momentarily disconnects the detection zone(s) under test and simulates the worst-case condition for fault.

A resistor load equal to worst case fault is placed on the zone continuously for 5 seconds then the zone is returned back to its normal condition.

If several zones are being tested consecutively and are being entered at a rate faster than the 5-second fault timer, the fault timeout will occur 5 seconds after the last entry was completed.

Once the zone has registered a fault, all outputs relating to that zone are initiated similar to a real fault.

The zone may be isolated prior to a fault test if desired. This will prevent any outputs from operating.

'#' in the above key sequence is the zone number.

If only one zone is to be tested, use the appropriate zone number. Alternatively the "ALL" button can be used to simultaneously test all zones.

To perform a fault test on a particular zone or on all zones:

1. Press the "FAULT TEST" button once.
The buzzer will give 2 short beeps to indicate that fault test mode has been entered.
2. The LCD display will read "FAULT TEST MODE, ENTER ZONE No.".
3. Enter the zone number ("#") 1-64 or "all".
4. Press "ENTER".

A long beep will signify an incorrect entry and the panel will revert back to normal operating mode. The "FAULT TEST" button will need to be pressed again to re-enter fault test mode.

If a correct entry is made, fault testing on the zone commences and the fault LED will illuminate.

ISOLATE

ISOLATE**#****ENTER**

The isolate function prevents the transmission of alarms or faults from the zones, to the master alarm facility.

'#' in the above key sequence is the zone number.

If only one zone is to be isolated, use the appropriate zone number. Alternatively the "ALL" button can be used to simultaneously isolate all zones.

To isolate a particular zone or all zones:

1. Press the "ISOLATE" button.
The buzzer will give 2 short beeps to indicate that isolate mode has been entered.
2. The LCD display will read "ALARM ISOL. MODE, ENTER ZONE No."
3. Enter the zone number ("#")1-64 or "all".
4. Press "ENTER".

A long beep will signify an incorrect entry and will revert back to normal operating mode. The "ISOLATE" button will need to be depressed again to re-enter isolate mode.

If a correct entry is made, the zone is immediately isolated. If the zone is already in alarm, all of its alarm outputs are isolated and indicators remain visible.

If the "ALL" function is performed, all zones will be isolated, regardless of their previous state. Performing the "ALL" function for a second time will de-isolate all zones.

RESET

RESET**#****ENTER**

The reset function momentarily disconnects power, and resets all alarm parameters for the zone(s) being reset. This returns the zone back to its "normal" state.

'#' in the above key sequence is the zone number.

If only one zone is to be reset, type in the zone number. Alternatively the "ALL" button can be used to simultaneously reset all zones.

To perform a reset on a particular zone or on all zones:

1. Press the "RESET" button.
The buzzer will give 2 short beeps to indicate that reset mode has been entered.
2. The LCD display will read "ALARM RESET MODE, ENTER ZONE NO".
3. Enter the zone number ("#") 1-64 or "all".
4. Press "ENTER".

A long beep will signify an incorrect entry and will revert back to normal operating mode. The "RESET" button will need to be depressed again to re-enter reset mode.

If a correct entry is made, resetting of the zone begins immediately. Any alarm indication will be removed immediately; also resetting the zone(s) programmed outputs.

PROGRAMMING

GLOBAL OPTIONS

ANCILLARY TRIP		
1	LATCHING	NORMALLY DE-ENERGISED
2	NON-LATCHING	NORMALLY DE-ENERGISED
3	LATCHING	NORMALLY ENERGISED
4	NON-LATCHING	NORMALLY ENERGISED

ALARM VERIFICATION	
1	DISABLED
2	2 MINUTES
3	3 MINUTES
4	4 MINUTES
5	5 MINUTES

TIME
(DD) / (MM) / (YY)
(HH) : (MM)

ZONE OPTIONS

	DESCRIPTION	INPUT DELAY
1	Standard Latching	2 seconds
2	Standard Latching	2 seconds with AVF
3	Non Latching	2 seconds
4	Non Latching	20 seconds
5	Time Delay	10 seconds
6	Time Delay	20 seconds
7	Time Delay	30 seconds
8	Time Delay	40 seconds
9	Time Delay	50 seconds
10	Time Delay	60 seconds

Type	Output Description
1	Indicate Only
2	Indicate, Bell
3	Indicate, Bell, General Alarm
4	Indicate, Bell, General Alarm, Ancillary
5	Indicate, Bell, General Alarm, Ancillary, Brigade Relay #1
6	Indicate, Bell, General Alarm, Ancillary, Brigade Relay #2
7	Indicate, Bell, General Alarm, Ancillary, Brigade Relay #1, & Brigade Relay #2

OUTPUT RELAY OPTIONS

Optional Relays can be programmed to simulate: -

- Isolate Relay
- ACF Output
- Brigade Relay #1
- Brigade Relay #2
- Fault Relay
- Mains Fail Relay
- General Alarm Relay
- Bell Output
- Door Holder Relay
- Door Switch
- Reset

Or Can Be Used To:

- "MAP AND" Up to 5 Zones in Alarm
- "MAP OR" Up to 5 Zones in Alarm
- "MAP FAULT" Up to 5 Zones in Fault
- "MAP ISOLATE" Up to 5 Zones in Isolate
- "MAP ISO/FAULT" Up to 5 Zones in Isolate/Fault

DEFAULT SETTINGS

ACF OUTPUT	NON-LATCHING, NORMALLY DE-ENERGISED
ALARM VERIFICATION (AVF)	3 MINUTES
TIME	1/1/11 11:11
ZONE TYPES	STANDARD LATCH 2S
ZONE OUTPUT CONFIG	I-B-G-A-BR1 & BR2
RELAY MAPPING	MAP -OR-, MAPPING = 1 TO 1 IE: RELAY 1 = ZONE 1, RELAY 2 = ZONE 2.....

The **2600** PANEL is self-configuring on power-up therefore it is not necessary to program the number of relay boards.

Zone expansion boards fitted must have the correct jumper selected.

PROGRAM MODE

Press the following buttons in order shown to enter programming mode.



PROGRAMMING MODE

The liquid crystal display will display all messages and prompts required to program the **2600**.

ONLY the "PREVIOUS", "NEXT", "SELECT", "EXIT" AND "ENTER" keys are used in programming mode. All other keys will give an error beep and are ignored.

Alarm detection is not affected during the programming function but you must exit programming mode if any other panel functions are to be performed including acknowledge and reset of alarms.

Note: Refer to appendices for detailed explanation of functions

PROGRAMMING HIERARCHY

EXIT	
SAVE CHANGES	
YES	NO

ZONES	RELAY
GLOBAL	PRINT

ZONES

TYPE
STD LATCHING
STANDARD LATCHING AVF
NON LATCH
NON LATCH 20S
TIME DELAY 10S
TIME DELAY 20S
TIME DELAY 30S
TIME DELAY 40S
TIME DELAY 50S
TIME DELAY 60S

OUTPUT
INDICATE
I BELL
IB GENERAL
IBG ACF OUT
IBGA BRIGADE 1
IBGA BRIGADE 2
IBGA BRIGADE 1 & 2

RELAYS

TYPE	MAPPING
ISOLATE RELAY	
ANCILLARY OUTPUT (ACF)	
BRIGADE RELAY #1	
BRIGADE RELAY #2	
FAULT RELAY	
MAINS FAIL RELAY	
GENERAL ALARM RELAY	
BELL OUTPUT	
DOOR HOLDER RELAY	
MAP - AND	(00)(00)(00)(00)(00)
MAP - OR	(00)(00)(00)(00)(00)
MAP - FAULT	(00)(00)(00)(00)(00)
MAP - ISOLATE	(00)(00)(00)(00)(00)
MAP - ISOLATE / FAULT	(00)(00)(00)(00)(00)
DOOR SWITCH	
RESET	

GLOBAL

ACF	AVF	RELAY	TIME
NON-LATCHING ND	DISABLED	MAP RELAY (XX) >>>	(DD) / (MM) / (YY)
LATCHING ND	2 MINUTES	FROM ZONE XX	(HH) : (MM)
NON-LATCHING NE	3 MINUTES		
LATCHING NE	4 MINUTES		
	5 MINUTES		

ND: = NORMALLY DE-ENERGISED

NE: = NORMALLY ENERGISED

PRINT

PRINT
PRINTS OUT CURRENT CONFIGURATION

MAIN MENU

(ZONES)	RELAYS
GLOBAL	PRINT

Use the "NEXT" & "PREVIOUS" keys to scroll through "ZONES" "RELAYS" "GLOBAL" "PRINT" and wrap around. Once the desired option has been highlighted, pressing the "SELECT" button will select it.

Pressing "EXIT" at this stage will exit programming mode.

EXIT PROGRAMMING MODE

SAVE CHANGES
YES (NO)

Use the "NEXT" & "PREVIOUS" keys to scroll through "YES" & "NO". Once the desired option has been highlighted, pressing the "SELECT" button will select it.

Highlighting "YES" and pressing "SELECT" will write all changes made to the system memory (E²ROM) and the panel will then restart.

WARNING!! The above action cause the panel to drop any door holders / air-conditioning if connected.

Highlighting "NO" and pressing "SELECT" will ignore any changes made to the programming and exit back to normal panel operation without restarting.

Note: This does not apply to saving changes to the time. Changes to time are saved immediately the select key is pressed when in the time adjustment menu.

ZONE PROGRAMMING

SELECT ZONE

SELECT ZONE #
(ALL)

Use the "NEXT" & "PREVIOUS" keys to scroll through "ALL" "1" "2" "3"

Up to the maximum number of zones fitted and then wrap around. Once the desired zone number has been highlighted, pressing the "SELECT" button will select it. Pressing "EXIT" at this stage will return to main menu.

ZONE SELECTED

ZONE # ALL
(TYPE) OUTPUT

Use the "NEXT" & "PREVIOUS" keys to scroll through "TYPE" & "OUTPUT". Once the desired option has been highlighted, pressing the "SELECT" button will select it. Pressing "EXIT" at this stage will return "SELECT ZONE #".

ZONE TYPE

ZONE # ALL TYPE
STD LATCHING

Use the "NEXT" & "PREVIOUS" keys to scroll through

STD LATCHING
STD LATCHING AVF
NON LATCH
NON LATCH 20S
TIME DELAY 10S
TIME DELAY 20S
TIME DELAY 30S
TIME DELAY 40S
TIME DELAY 50S
TIME DELAY 60S

Once the desired option has been highlighted, pressing the "SELECT" button will select it. Making a selection or pressing "EXIT" will return to zone selected.

Note: The option previously set is displayed in brackets and is the first to be displayed. Previously set options will not be displayed if "ALL" is selected.

A function of "BELL" also operates the WARNING SYSTEM.

ZONE OUTPUT CONFIGURATION

ZONE #ALL OUTPUT
IBGA BRIG 1&2

Use the "NEXT" & "PREVIOUS" keys to scroll through:

INDICATE
I BELL
IB GENERAL
IBG ACF OUT
IBGA BRIGADE 1
IBGA BRIGADE 2
IBGA BRIG 1&2

Once the desired option has been highlighted, pressing the "SELECT" button will select it. Pressing "EXIT" at this stage will return to "Zone Selected".

Note: The option previously set is displayed in brackets and is the first to be displayed. Previously set options will not be displayed if "ALL" is selected.

A function of "BELL" also operates the WARNING SYSTEM.

RELAY PROGRAMMING MODE

SELECT RELAY

SELECT RELAY#
(ALL)

Use the "NEXT" & "PREVIOUS" keys to scroll through "ALL" "1" "2" "3". Up to 64 and then wrap around. Once the desired relay number has been selected, pressing the "SELECT" button will select it. Pressing "EXIT" at this stage will return to main menu.

RELAY SELECTED

RELAY #ALL
(TYPE) MAPPING

Use the "NEXT" & "PREVIOUS" keys to scroll through "TYPE" & "MAPPING". Once the desired option has been highlighted, pressing the "SELECT" button will select it. Pressing "EXIT" at this stage will return to "Select Relay #".

RELAY TYPE

RELAY #ALL TYPE
(GENERAL)

Use the "NEXT" & "PREVIOUS" keys to scroll through:

ISOLATE
ANCILLARY
BRIGADE 1
BRIGADE 2
FAULT
MAINS FAIL
GENERAL
BELL
DOOR HOLDER
MAP -AND-
MAP -OR-
MAP -FAULT-
MAP -ISOLATE-
MAP -ISOLATE/FLT-
DOOR SWITCH
RESET

Once the desired option has been highlighted, pressing the "SELECT" button will select it. Making a selection or pressing "EXIT" will return to "Relay Selected".

Note: The option previously set is displayed in brackets and is the first to be displayed. Previously set options will not be displayed if "ALL" is selected.

RELAY MAPPING

RELAY #1 MAP
(00) 00 00 00 00

** Relay mapping can only be selected if the relay is set as a MAP type.

These 5 entry fields represent the zone numbers that the relay is to be mapped to and will be activated from.

Use the "NEXT" and "PREVIOUS" keys to increment/decrement the zone number within the brackets.

Use the "ENTER" key to move to the next field. Fields may be changed as required and set by pressing "SELECT".

Any fields left as (00) will be ignored.

Pressing "EXIT" at this stage will return to "RELAY # ".

Note: The option previously set is displayed in brackets and is the first to be displayed. Previously set options will not be displayed if "ALL" is selected.

GLOBAL PROGRAMMING

(ACF)	AVF
RELAY	TIME

Use the "NEXT", "PREVIOUS" & "SELECT" keys to select. Pressing "EXIT" will return to "Main Menu".

ACF OUTPUT

ACF OUTPUT
(NON-LATCH ND)

Use the "NEXT" & "PREVIOUS" keys to scroll through:

LATCHING ND
NON-LATCH NE
LATCHING NE

Note: The option previously set is displayed in brackets and is the first to be displayed.

ND = Normally De-energised i.e.: Output is not energised until an alarm occurs.

NE = Normally energised i.e.: Output is energised and then is de-energised once an alarm occurs.

AVF

AVF TIMEOUT
(3 MINUTES)

Use the "NEXT" & "PREVIOUS" keys to scroll through:

DISABLED
2 MINUTES
3 MINUTES
4 MINUTES
5 MINUTES

Note: The option previously set is displayed in brackets and is the first to be displayed.

RELAY (GLOBAL RELAY UNITY MAP)

MAP RELAY (XX) >>
FROM ZONE (XX)

Use the "NEXT" & "PREVIOUS" keys to change the first relay to start from, together with the matching zone. Use the "ENTER" key to toggle between the two and press "SELECT" once finalised. "Exit" will abort unity map.

This function will start programming relays starting from the relay number specified in a 1 to 1 configuration with zones starting from the first zone number specified.

Example 1: if the above table was to look like this:

MAP RELAY (10) >>
FROM ZONE (01)

Then relay #10 would be set as MAP OR with its mapping as (01) 00 00 00 00, relay #11 would be set as MAP OR with its mapping set as (02) 00 00 00 00 and so on all the way up to relay #64. Relays number 1-through 9 remains unaffected by this function.

Example 2: if the above table was to look like this:

MAP RELAY (01) >>
FROM ZONE (09)

Then relay #1 would be set as MAP OR with its mapping as (09) 00 00 00 00, relay #2 would be set as MAP OR with its mapping set as (10) 00 00 00 00 and so on all the way up to relay #64.

Note: In example 2, zone number 64 is reached and there are still more relays to go. (I.e. we are only at relay #56) the programming stops at this point and any relays not yet programmed will be left in their previous programmed mode and are unaffected by this function.

PRINT PROGRAMMING DATA

Prints the programming data currently stored in RAM, including all changes made (they may have not yet been written to the E2ROM).

Output is printed directly onto the serial printer if fitted.

TIME (DATE & TIME)

The current DATE & TIME will be displayed as DD/MM/YY (in 24h format)

Use the PREVIOUS" & NEXT" keys to increment or decrement the number highlighted by brackets.

The ENTER key will move to the next field.

When finished, the SELECT key must be pushed to store the date/time.

Note:

The Date/Time data is saved when the Select key is pushed.

DO NOT select "Save Changes "Y" as this will restart (and drop any door holders / air-conditioning if connected).

APPENDIX A

DESCRIPTION OF ALARM ZONE TYPES

Different zone types can be selected using the programming mode. Each zone can be selected as any one of the following:

Type	Description	Input Delay
1	Standard Latching	2 seconds
2	Standard Latching	2 seconds with AVF
3	Non Latching	2 seconds
4	Non Latching	20 seconds
5	Time Delay	10 seconds
6	Time Delay	20 seconds
7	Time Delay	30 seconds
8	Time Delay	40 seconds
9	Time Delay	50 seconds
10	Time Delay	60 seconds

LATCHING TYPE

Once an alarm condition is received from the detector, the alarm zone will start a timer, if after 2 seconds the detector is still activated the alarm zone will register an alarm condition. Indicators will illuminate and alarm functions are initiated immediately, unless zone is set as AVF - refer Appendix C. The alarm zone will remain in alarm until manually reset.

A reset is performed by interrupting the power to the detector for 0.5 seconds and returning the alarm zone back to its quiescent state. If an alarm is still present in the detector area, the detector will re-activate and the 2-second timer will be re-initiated.

NON LATCHING TYPE

A temporary actuation device (e.g. Flow Switch) is usually connected to this type of alarm zone. Once a signal has been received CONTINUOUSLY for 2 seconds or 20 seconds (dependant on programming) an alarm will be registered causing the alarm LED to flash and alarm functions will be performed as programmed.

The alarm group will remain in alarm until the actuating device no longer reports a signal. When actuating device signal is clear, the alarm is cleared, causing the zone to power down for 0.5 seconds and return back to normal state.

TIME DELAY AZF

The time delay AZF zone can be preset to any one of 6 time delays in the initial setup. This type of zone is used for AS1668 smoke detection zones. Zone timing etc is as per AS1668-1991.

Example: Timer #1 = 60 seconds

Once the first alarm is received, the alarm LED is turned on steady; this indicates "PARTIAL ALARM" condition.

The detector is then reset (by removing its power for 0.5 seconds) and a timer is also started for 60 seconds (TIMER#1). Another timer of 10 seconds (TIMER#2) is also started. The zone must respond again within this 10 seconds (TIMER#2) to register another alarm.

Failure to receive another alarm within this 10-second period will return the zone back to its normal state immediately and extinguish the alarm LED.

If an alarm is received, the detector is reset again and TIMER#2 is also reset.

This monitoring continues until the 60-second timer (TIMER#1) has elapsed and then the NEXT alarm signal will trip the zone into "FULL ALARM". This is the stage at which all mapped relays, bells etc. will operate.

When "FULL ALARM" condition is reached, a third timer (TIMER#3) of 70 seconds is started. This timer is used to prevent "hunting" of air conditioning fans as specified in AS1668

TIMER#2 is kept operating and alarm signals are still to be received as per previous. Alarm signals are required continually to keep the zone in "FULL ALARM". Each time another alarm is received Timer#3 is restarted (i.e. 70 seconds)

Failure to comply with TIMER#2 will result in the zone being returned back to its **NORMAL** state once TIMER#3 has elapsed.

APPENDIX B

ZONE OUTPUT CONFIGURATIONS

Once a zone has alarmed, its output functions as programmed to one of the following output types.

Type	Output Description
1	Indicate Only
2	Indicate, Bell
3	Indicate, Bell, General Alarm
4	Indicate, Bell, General Alarm, Ancillary
5	Indicate, Bell, General Alarm, Ancillary, Brigade Relay #1
6	Indicate, Bell, General Alarm, Ancillary, Brigade Relay #2
7	Indicate, Bell, General Alarm, Ancillary, Brigade Relay #1, & Brigade Relay #2

NOTE: A function of "BELL" also operated the WARNING SYSTEM.

Refer to technical specification for descriptions of output types.

The zone can also be programmed to operate one (1) or more relay contacts through the use of the relay mapping output feature.

APPENDIX C

ALARM VERIFICATION FACILITY (AVF)

Alarm verification (AVF) is a facility used to minimise false alarms.

AVF only applies to the zones programmed for the AVF function.

GLOBAL PROGRAMMABLE OPTIONS

AVF TIMEOUT
Disabled
2 Minutes
3 Minutes
4 Minutes
5 Minutes

Operation is as follows:

If a zone is programmed as AVF and it registers an alarm, no alarm functions are performed, if it is the first AVF zone in alarm.

This zone and all other zones programmed as AVF zones are reset by shutting down power to their detectors for 12 seconds, the power is then restored and the zones are re-enabled.

The alarm verification zones are now in "alert" mode. Any AVF zone going into alarm within the pre-selected timeout period (2,3,4,5 minutes) will then cause an immediate alarm condition with all the programmed output functions being initiated.

If no alarm is received within this period, the AVF zones are removed from the "alert" mode and returned to normal. A further alarm will re-initiate the reset sequence etc.

Other zones are unaffected by the actions of AVF zones. They will all function as normal, regardless of AVF zone status.

If the timeout period is disabled, the alarm will transmit instantly thus making the AVF non-functional.

APPENDIX D

ANCILLARY TRIP (ACF)

The ancillary trip is used for the shutting down of air conditioning systems etc. in the event of a fire.

GLOBAL PROGRAMMABLE OPTIONS

ANCILLARY TRIP (ACF)	
NON-LATCHING	ND
LATCHING	ND
NON-LATCHING	NE
LATCHING	NE

The ancillary trip can be programmed as latching or non-latching depending on the application.

It can also be programmed as normally energised or normally de-energised.

If a zone is programmed to operate the ancillary trip, an alarm condition will energise the ancillary trip until the alarm is removed (if non-latching), or until the alarm is removed and the ACF is manually reset via the keypad (latching).

APPENDIX E

RELAY OUTPUT MAPPING

A total of 64 expansion relays can be fitted to the IFS-2600. Each relay can be individually programmed to mimic any of the following;

STANDARD OUTPUTS WHICH MAY BE MIMICED

ANCILLARY OUTPUT (ACF)
BRIGADE ALARM RELAY #1
BRIGADE ALARM RELAY #2
* FAULT RELAY (NORMALLY ENERGISED)
* MAINS FAIL RELAY (NV) (NORMALLY ENERGISED)
ISOLATE RELAY
GENERAL ALARM RELAYS
BELL OUTPUT
DOOR SWITCH
RESET
DOOR HOLDER RELAY
FAULT/ISOLATE

When mapping to a normally energised relay, take care to ensure that connections take into account the normally energised state of the relay.

Alternatively, the expansion relay(s) can be mapped to provide customised logic to suit specific installations:

AND MAPPING

AND MAPPING allows the relay output to be programmed for a combination of up to 5 zones, and only after they **all** go into alarm, will the relay operate.

AND MAPPING is useful for applications which have special shutdowns, multiple risk Gas Facilities etc.

OR MAPPING

OR MAPPING works similarly. This function will cause the relay to operate if **any** one of up to five (5) zones go into alarm, the relay will operate.

If the relay map options are set as "01" "02" "03" "00" "00", zones 1 or 2 or 3 in alarm will cause the relay to operate.

OR MAPPING is useful for applications which have special shutdowns, zoned mimic outputs etc.

FAULT MAPPING

FAULT MAPPING works the same as OR mapping of alarm except it relates to the fault flag on each zone instead of the alarm flag. This function will cause the relay to operate if **any** one of up to five (5) zones go into fault.

If the relay map options are set as "01" "02" "03" "00" "00", then zones 1 or 2 or 3 going into fault, will cause the relay to operate.

FAULT/ISOLATE MAPPING

FAULT/ISOLATE MAPPING works the same as OR mapping of alarm except it relates to the fault/isolate flag on each zone instead of the alarm flag. This function will cause the relay to operate if **any** one of up to five (5) zones go into fault/put in isolate.

If the relay map options are set as "01" "02" "03" "00" "00", then zones 1 or 2 or 3 going into fault/(or are manually put in isolate) will cause the relay to operate.

ISOLATE MAPPING

ISOLATE MAPPING works the same as or mapping of alarm except it relates to the isolate flag on each zone instead of the alarm flag. This function will cause the relay to operate if **any** one of up to five zones is put in isolate.

If the relay map options are set as "01" "02" "03" "00" "00", then zones 1 or 2 or 3, if put in isolate will cause the relay to operate.

APPENDIX F

GLOSSARY OF TERMS

AS-4428.1	Australian standard for; - Automatic Fire Detection and Alarm Systems Control and Indicating Equipment.
AS-4428.1	Australian standard for; - Automatic Fire Detection and Alarm Systems Power Supply Units.
AS-1670	Australian standard for; - Automatic Fire Detection and Alarm Systems System Design Installation and Commissioning.
AS-1668.1	Australian standard for; - SAA Mechanical Ventilation and Air Conditioning Fire Precautions in Buildings with Air-handling Systems.
AZF	Alarm Zone Facility (zone)
MAF	Master Alarm Facility
ACF	Ancillary Control Facility
AVF	Alarm Verification Facility
ISOL	Isolate
FLT	Fault
ZONE	Alarm Zone Facility
DET	Detector
LED	Light Emitting Diode
LCD	Liquid Crystal Display
A/C	Air Conditioning
AC	Alternating Current
DC	Direct Current
V	Voltage
A	Amps
FIP	Fire Indicator Panel
N/L	Non Latching
TD	Time Delay
STD	Standard
SBY	Standby
BR1	Brigade Relay 1
BR2	Brigade Relay 2
NV	AC Fail Relay
IS	Isolate
GEN	General Alarm Contacts
D/H	Door Holder
RLY	Relay

APPENDIX G

SUMMARY OF TERMINATIONS AND CAUTIONS

MCP LOOP

Used for the looping of the manual call point to a particular zone chosen for indication. This is achieved by wiring from the zone, to the MCP, to the MCP loop then out to the field with the EOL across the last detector. The MCP is the first device on the circuit and both fault and alarm conditions will be indicated.

DETECTION ZONES

Refer to list of compatible actuation devices for detectors which may be used. Any other hard contact device may be used on these detection zones. An end of line resistor (E.O.L) of 4K7 ohms is required.

RELAY OUTPUTS

Relay outputs are voltage free change over contacts rated at 24VDC 1Amp (resistive). DO NOT attempt to switch 240VAC with these relay contacts.

Note: Relay Contacts Shown At Terminals (NC, C, NO) Are For The Relay In a De-energised State.

BELL OUTPUTS

This output is fused at 1 Amp and can drive up to 10 NIFS bells as specified. Output is also monitored and if no bells are connected an EOL resistor (4K7 ohms) is required across the output terminals.

ACF OUTPUTS

This output is fused at 1 Amp. Output is also monitored and if no ancillary devices are connected, an EOL resistor (4K7 ohms) is required across the output terminals.

WARNING SYSTEM

Connection for warning systems such as Occupant Warning System or electronic sounders.

DOOR HOLDER OUTPUTS

When a door holder transformer is fitted to the panel, this output becomes functional. Output is rated at 3 Amps maximum and can power up to 30 NIFS style door holders continuously. (Nom. 80mA each). Output is separately fused at 3A (FS-1). Jumper JP3 if fitted will disable this output, i.e. 24V DC output all the time. The Door Holder Output can be isolated using the ACF Isolate function.

AUXILIARY POWER & MIMIC POWER

A total auxiliary power draw of 500mA is available from the auxiliary power and mimic power terminals. This output is fused at 1 Amp (FS-3) and is battery backed.

MAF ISOL & TRANSPONDER 0V

A 0V signal is switched back from the transponder test switch and is used for indication purposes at the FIP. This will indicate as MAF ISOLATED and initiate a common fault. It can also be used for an external device to indicate a fault.

MIMIC DATA & CLOCK

These outputs together with the mimic power terminals are used to serially communicate with the mimic panels when fitted. EOL resistor is not required on these lines.

NOTE: Firmware must be Version 6 or above for mimic operation

AC INPUT

Mains step down transformer output (30VAC) is connected at these terminals. **DO NOT** connect 240VAC to these terminals.

BATTERY

The 24V batteries are connected at these terminals. Reverse polarity will cause serious and permanent damage to the equipment.

DOOR HOLDER AC INPUT

Terminate the door holder AC transformer at these terminals. 24 VAC is the only acceptable power source at this point. **DO NOT** connect 240VAC at this point.

OUTPUT RELAYS

STANDBY (N) Normally energised, drops out when power supply (or battery supply) is below specified voltage.

BRIGADE1 Brigade 1, defaults as energising on any alarm zone, programmable.

BRIGADE2 Brigade 2, defaults as energising on any alarm zone, programmable.

FAULT (N) Normally energised, drops out on any fault unless that function is isolated.

AC-FAIL (N) Normally energised, drops out if the mains power is lost.

ISOLATE Energised if any zone is isolated.

GENERAL1 Energised if any zone goes into alarm

GENERAL2 Energised if any zone goes into alarm

ZONE TYPE PROGRAMMING	Date: / /
-----------------------	-------------------

	1	2	3	4	5	6	7	8	9	10
AZF No.	STD 2S	STD AVF	N/L 2S	N/L 20S	T/D 10S	T/D 20S	T/D 30S	T/D 40S	T/D 50S	T/D 60S
1										
2										
3										
4										
5										
6										
7										
8										
9										
10										
11										
12										
13										
14										
15										
16										
17										
18										
19										
20										
21										
22										
23										
24										
25										
26										
27										
28										
29										
30										
31										
32										

Place an "X" in the appropriate box

= Default

	1	2	3	4	5	6	7	8	9	10
AZF No.	STD 2S	STD AVF	N/L 2S	N/L 20S	T/D 10S	T/D 20S	T/D 30S	T/D 40S	T/D 50S	T/D 60S
33										
34										
35										
36										
37										
38										
39										
40										
41										
42										
43										
44										
45										
46										
47										
48										
49										
50										
51										
52										
53										
54										
55										
56										
57										
58										
59										
60										
61										
62										
63										
64										

Place an "X" in the appropriate box

 = Default

ZONE OUTPUT PROGRAMMING	Date: / /
--------------------------------	-------------------

AZF No.	INDICATE	I- BELL	IB- GENERAL	IBG- ACF	IBGA- BR1	IBGA- BR2	IBGA- BR1&BR2
1							
2							
3							
4							
5							
6							
7							
8							
9							
10							
11							
12							
13							
14							
15							
16							
17							
18							
19							
20							
21							
22							
23							
24							
25							
26							
27							
28							
29							
30							
31							
32							

Place an "X" in the appropriate box = Default

AZF No.	INDICATE	I-BELL	IB-GENERAL	IBG-ACF	IBGA-BR1	IBGA-BR2	IBGA-BR1&BR2
33							
34							
35							
36							
37							
38							
39							
40							
41							
42							
43							
44							
45							
46							
47							
48							
49							
50							
51							
52							
53							
54							
55							
56							
57							
58							
59							
60							
61							
62							
63							
64							

Place an "X" in the appropriate box

 = Default

RELAY OUTPUT MAPPING	Date: / /
----------------------	-----------------

RLY	ISO	ACF	BR1	BR2	FLT	MAINS FAIL	GEN	BELL	D/H	MAPPING						DO- OR	RE- SET
										AND	OR	FLT	ISO	ISO/ FLT			
1																	
2																	
3																	
4																	
5																	
6																	
7																	
8																	
9																	
10																	
11																	
12																	
13																	
14																	
15																	
16																	
17																	
18																	
19																	
20																	
21																	
22																	
23																	
24																	
25																	
26																	
27																	
28																	
29																	
30																	
31																	
32																	

Place an "X" in the appropriate box

= Default

RLY	ISO	ACF	BR1	BR2	FLT	MAINS FAIL	GEN	BELL	D/H	MAPPING					DO- OR	RE- SET
										AND	OR	FLT	ISO	ISO/ FLT		
33																
34																
35																
36																
37																
38																
39																
40																
41																
42																
43																
44																
45																
46																
47																
48																
49																
50																
51																
52																
53																
54																
55																
56																
57																
58																
59																
60																
61																
62																
63																
64																

Block Connection Diagram

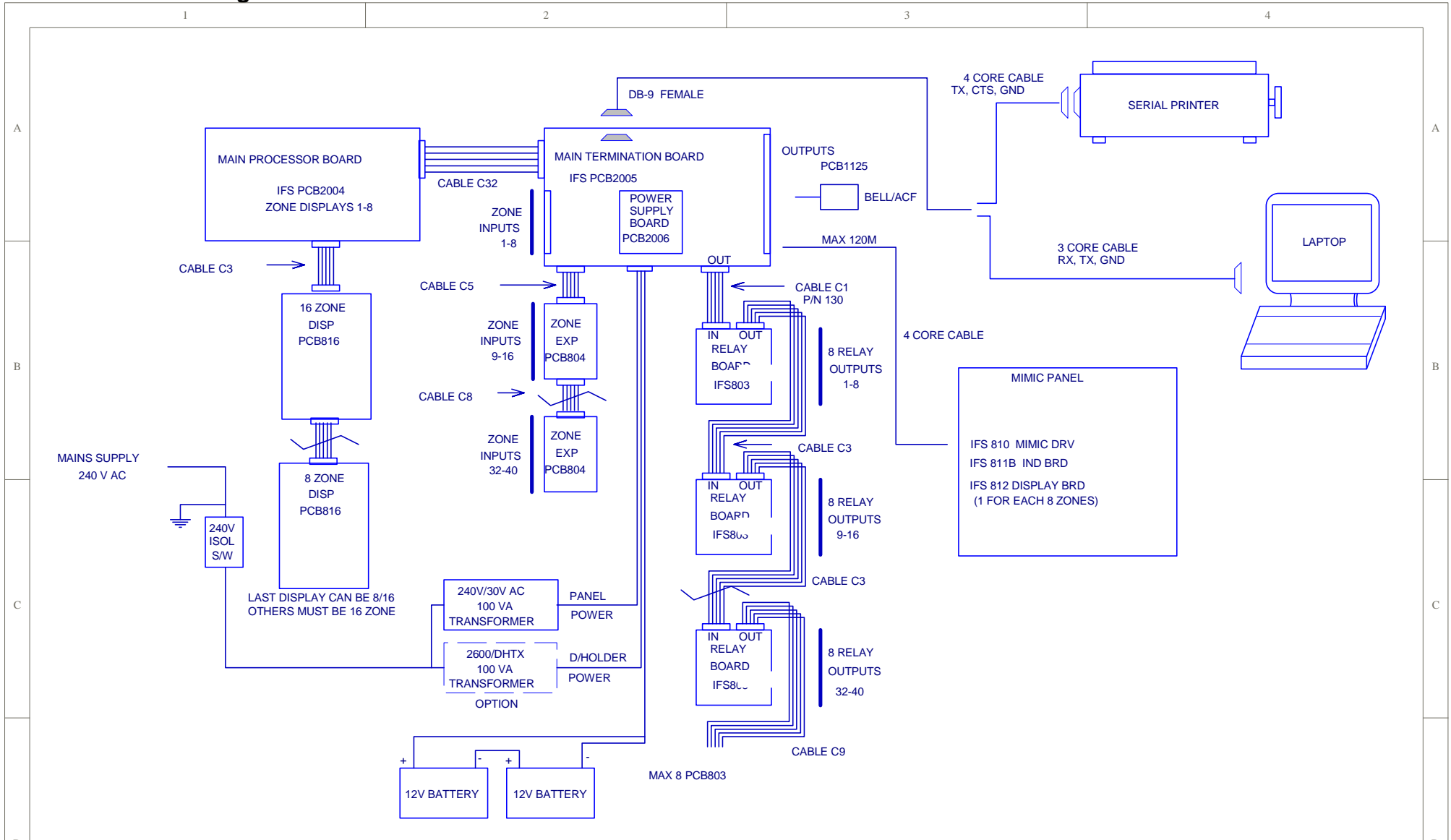

D	Removed Part Numbers	IP	IP	21/12/04
C	Revised Printer Connection	IP	IP	18/8/05
B	REVISED PART NUMBERS	G.W.	G.W.	9/3/04
No.	Revision - revise on CAD. Do not amend by hand	Eng.	App.	Date

Copyright
This document is & shall remain the property of
Notifier Inertia Fire Systems ©
Unauthorised use of this document in any way is prohibited.
Drawing File No.
-DocumentFullPathAndName



7 Columbia Court,
Norwest Business Park
Baulkham Hills NSW 2153
AUSTRALIA
Tel 61 2 9894 1444
Fax 61 2 9899 4156
Email: support@inertia.com.au

Sheet: 1	Of: 1
Drawn/Traced: 14/08/03	Engineer/Design: I.P.
Approved	
This Drawing must not be used for Construction unless signed as approved	

Title	
IFS2600 BLOCK CONNECTION DIAGRAM	
Size: A4	Drg. No.: L2600-1
Rev: D	

System Sensor Conventional Detector Connection Diagram

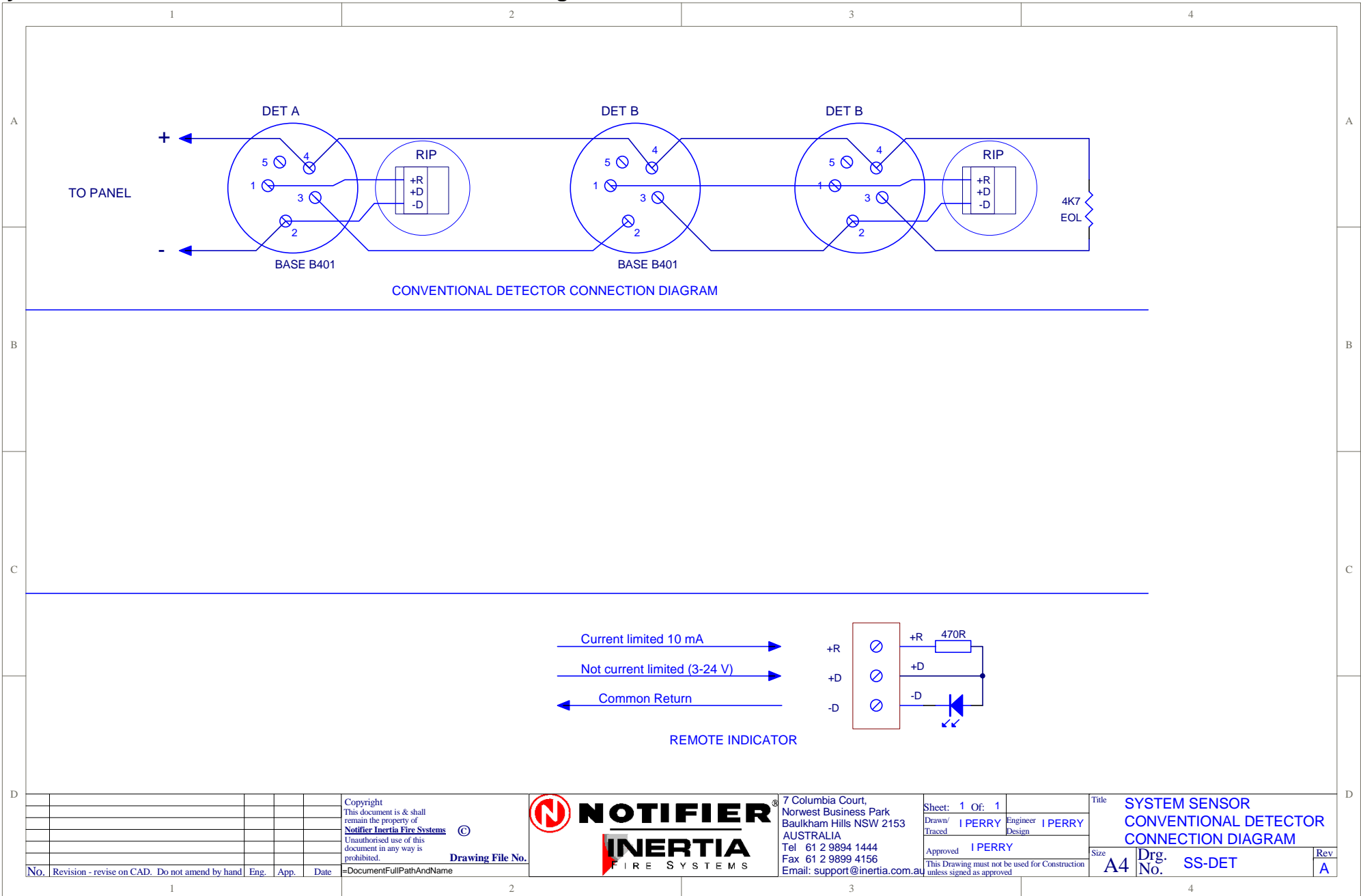

Hochiki Conventional Detector Connection Diagram

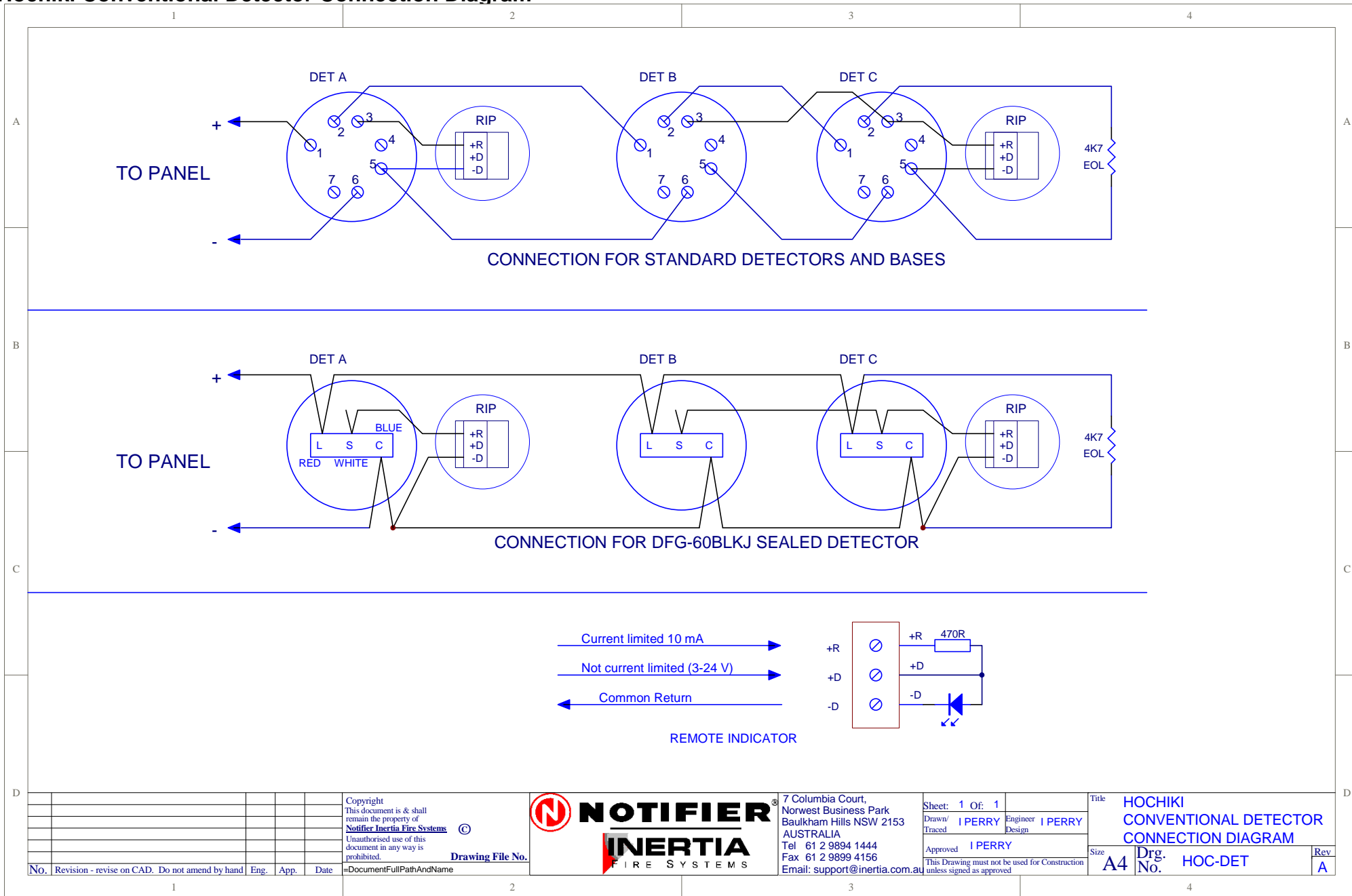

No.	Revision	Eng.	App.	Date

Copyright
 This document is & shall remain the property of
Notifier Inertia Fire Systems ©
 Unauthorised use of this document in any way is prohibited.
Drawing File No.



7 Columbia Court,
 Norwest Business Park
 Baulkham Hills NSW 2153
 AUSTRALIA
 Tel 61 2 9894 1444
 Fax 61 2 9899 4156
 Email: support@inertia.com.au

Sheet: 1 Of: 1
 Drawn/ Traced: I PERRY
 Engineer/ Design: I PERRY
 Approved: I PERRY

Title: HOCHIKI CONVENTIONAL DETECTOR CONNECTION DIAGRAM
 Size: A4
 Drg. No.: HOC-DET
 Rev: A

Ancillary Connection Diagram

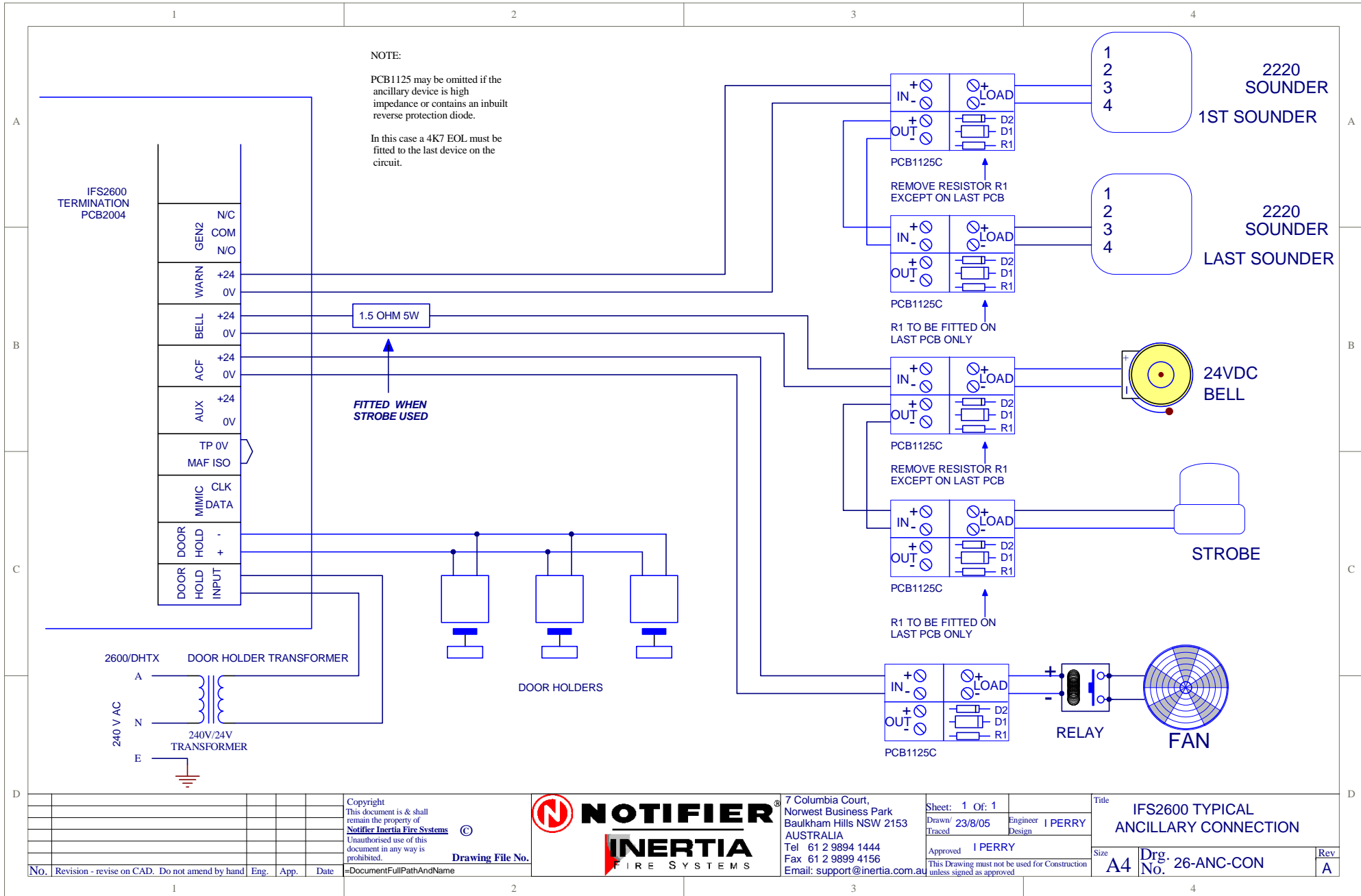

NO.	Revision - revise on CAD. Do not amend by hand	Eng.	App.	Date

Copyright
This document is & shall remain the property of
Notifier Inertia Fire Systems ©
Unauthorised use of this document in any way is prohibited.
Drawing File No.
=DocumentFullPathAndName



7 Columbia Court,
Norwest Business Park
Baulkham Hills NSW 2153
AUSTRALIA
Tel 61 2 9894 1444
Fax 61 2 9899 4156
Email: support@inertia.com.au

Sheet: 1 Of: 1
Drawn/ Traced 23/8/05
Engineer Design I PERRY
Approved I PERRY
This Drawing must not be used for Construction unless signed as approved

Title
IFS2600 TYPICAL ANCILLARY CONNECTION
Size A4
Drg. No. 26-ANC-CON
Rev A

ASE Connection Diagram

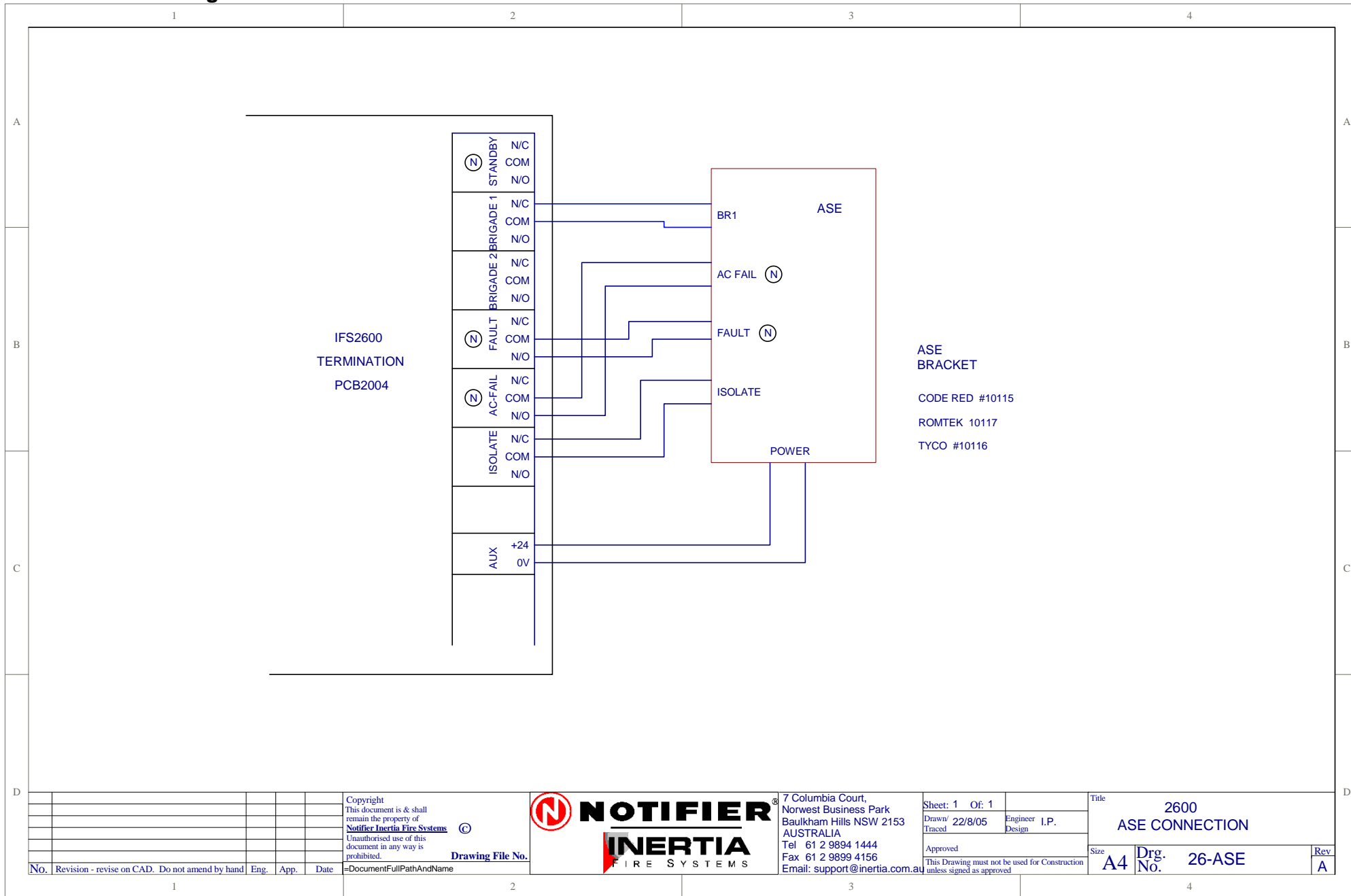

				Copyright This document is & shall remain the property of Notifier Inertia Fire Systems © Unauthorised use of this document in any way is prohibited.		7 Columbia Court, Norwest Business Park Baulkham Hills NSW 2153 AUSTRALIA Tel 61 2 9894 1444 Fax 61 2 9899 4156 Email: support@inertia.com.au	Sheet: 1 Of: 1	Engineer I.P. Design	Title 2600 ASE CONNECTION	
No.	Revision - revise on CAD. Do not amend by hand	Eng.	App.	Date			Drawing File No.	Drawn/ Traced 22/8/05	Approved	Size A4

Auto Changeover Dual Sounder Connection Diagram

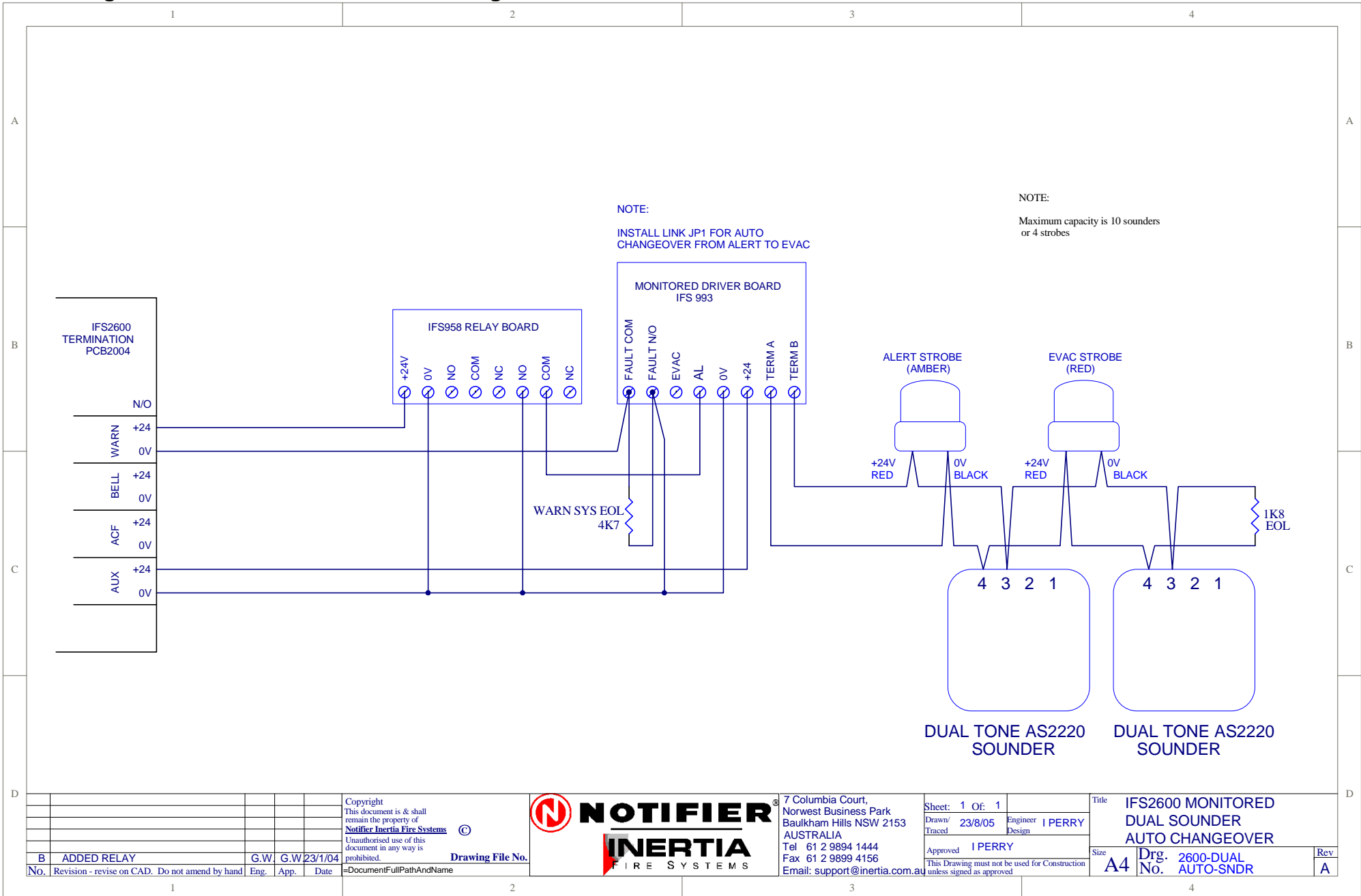

Auto Change Over Dual Sounder Connection Diagram

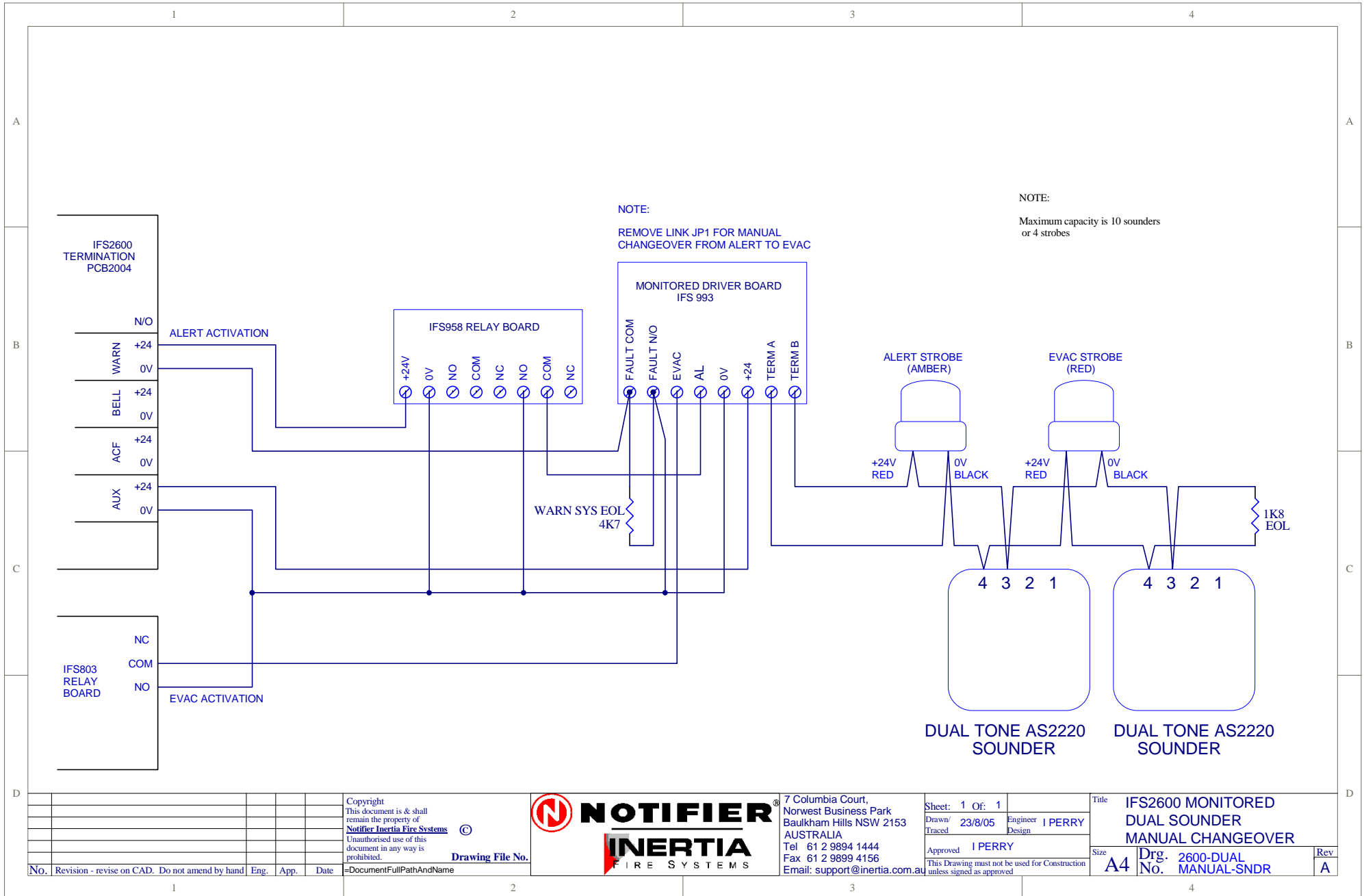

No.	Revision	Eng.	App.	Date

Copyright
This document is & shall remain the property of
Notifier Inertia Fire Systems ©
Unauthorised use of this document in any way is prohibited.
Drawing File No. _____
=DocumentFullPathAndName



7 Columbia Court,
Norwest Business Park
Baulkham Hills NSW 2153
AUSTRALIA
Tel 61 2 9894 1444
Fax 61 2 9899 4156
Email: support@inertia.com.au

Sheet: 1 Of: 1
Drawn/ Traced: 23/8/05
Engineer Design: I PERRY
Approved: I PERRY
This Drawing must not be used for Construction unless signed as approved

Title: IFS2600 MONITORED DUAL SOUNDER MANUAL CHANGEOVER
Size: A4
Drg. No.: 2600-DUAL MANUAL-SNDR
Rev: A

MIMIC Connection Diagram

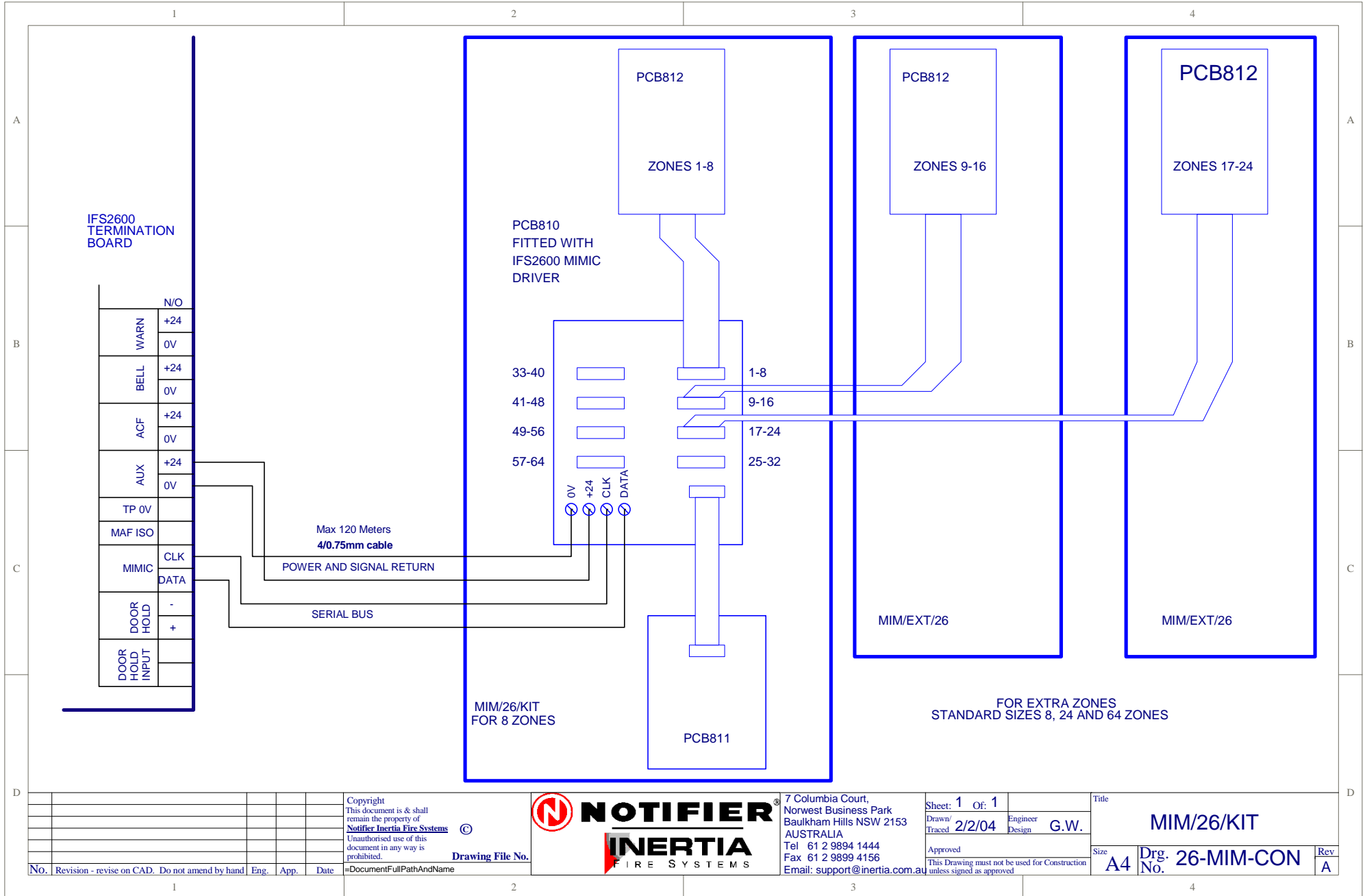

Single Fan Connection Diagram

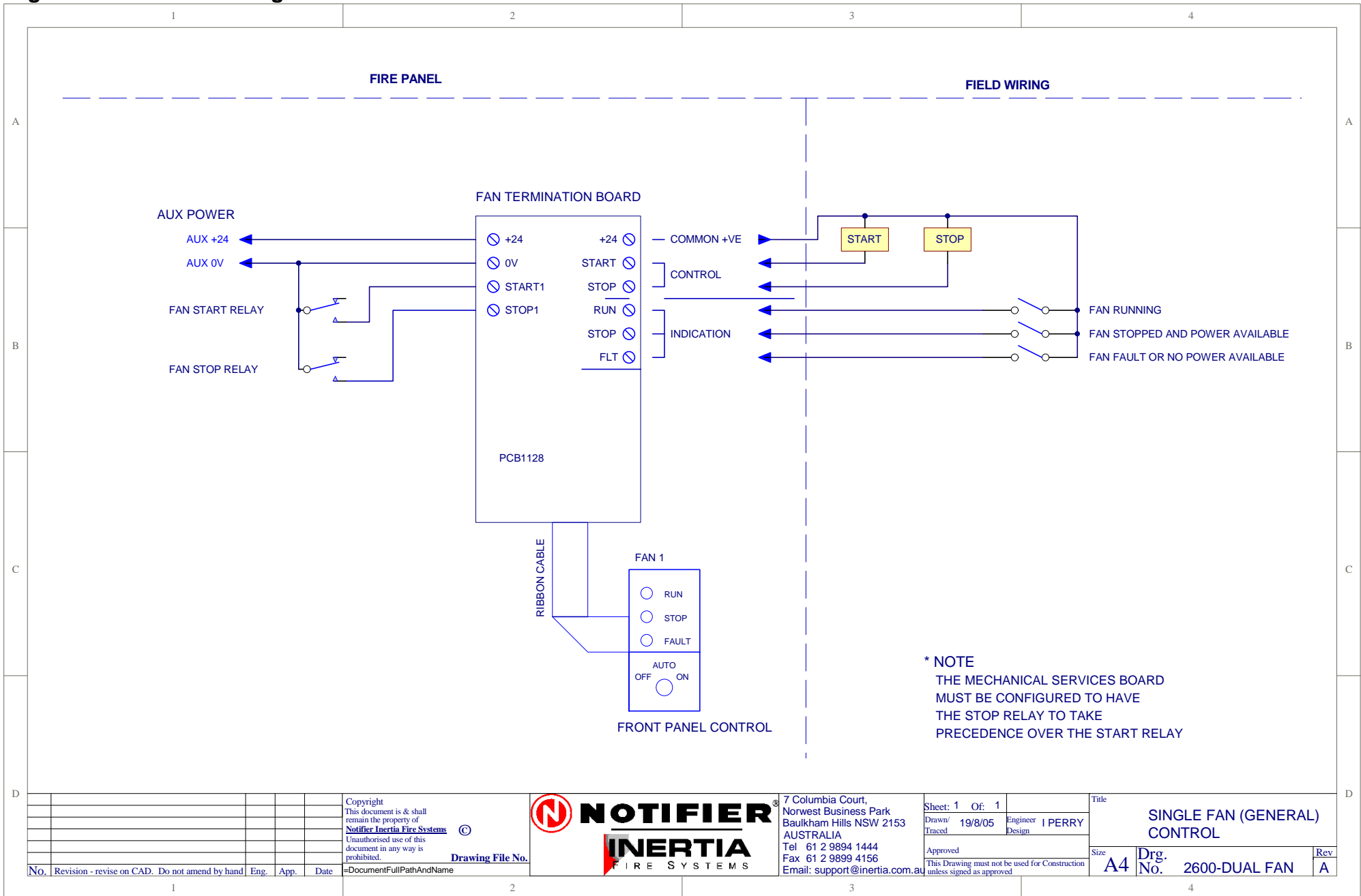

Copyright This document is & shall remain the property of Notifier Inertia Fire Systems © Unauthorised use of this document in any way is prohibited. Drawing File No.							7 Columbia Court, Norwest Business Park Baukham Hills NSW 2153 AUSTRALIA Tel 61 2 9894 1444 Fax 61 2 9899 4156 Email: support@inertia.com.au		Sheet: 1 Of: 1 Drawn/ 19/8/05 Traced Engineer PERRY Design Approved This Drawing must not be used for Construction unless signed as approved		Title SINGLE FAN (GENERAL) CONTROL		Size A4	Drg. No. 2600-DUAL FAN	Rev A
NO.	Revision - revise on CAD. Do not amend by hand	Eng.	App.	Date	=DocumentFullPathAndName										

Dual Fan Connection Diagram

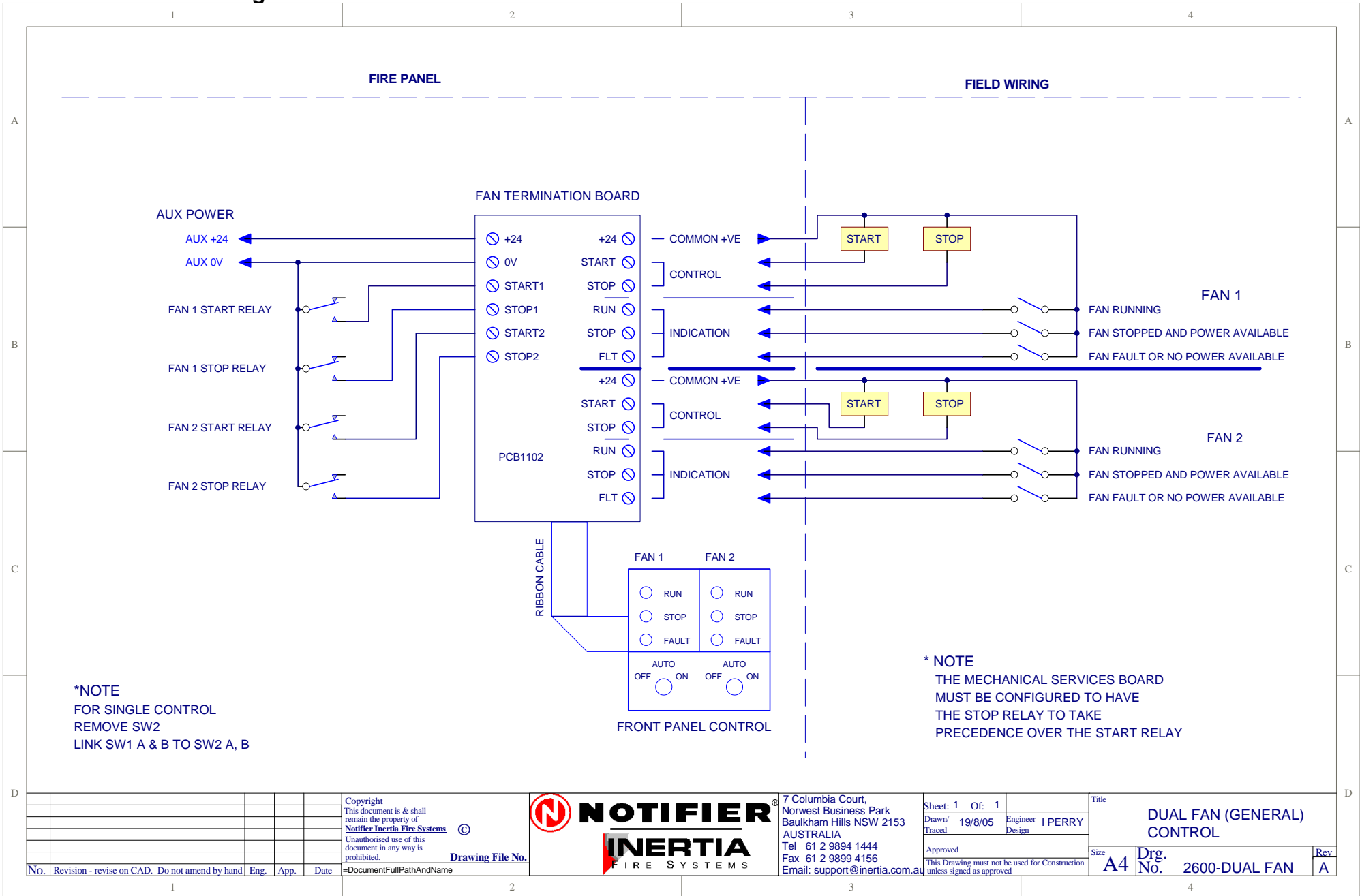

No.	Revision	Eng.	App.	Date

Copyright
This document is & shall remain the property of
Notifier Inertia Fire Systems ©
Unauthorised use of this document in any way is prohibited.
Drawing File No.
=DocumentFullPathAndName



7 Columbia Court,
Norwest Business Park
Baulkham Hills NSW 2153
AUSTRALIA
Tel 61 2 9894 1444
Fax 61 2 9899 4156
Email: support@inertia.com.au

Sheet: 1	Of: 1	
Drawn/ Traced	19/8/05	Engineer PERRY Design
Approved	This Drawing must not be used for Construction unless signed as approved	

Title		DUAL FAN (GENERAL) CONTROL	
Size	A4	Drg. No.	2600-DUAL FAN
Rev	A		

Exhaust Fan Connection Diagram

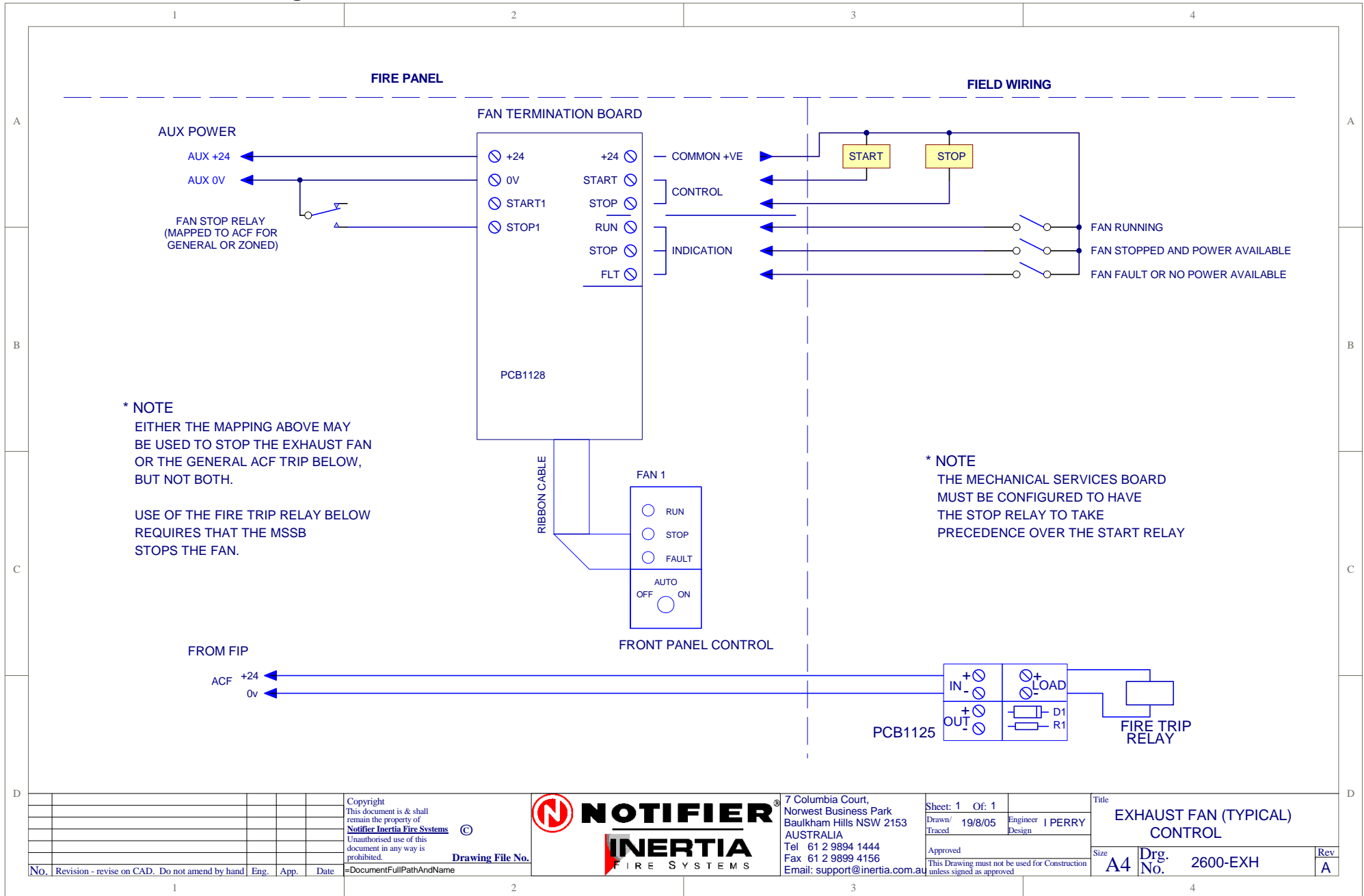

Supply Fan Connection Diagram

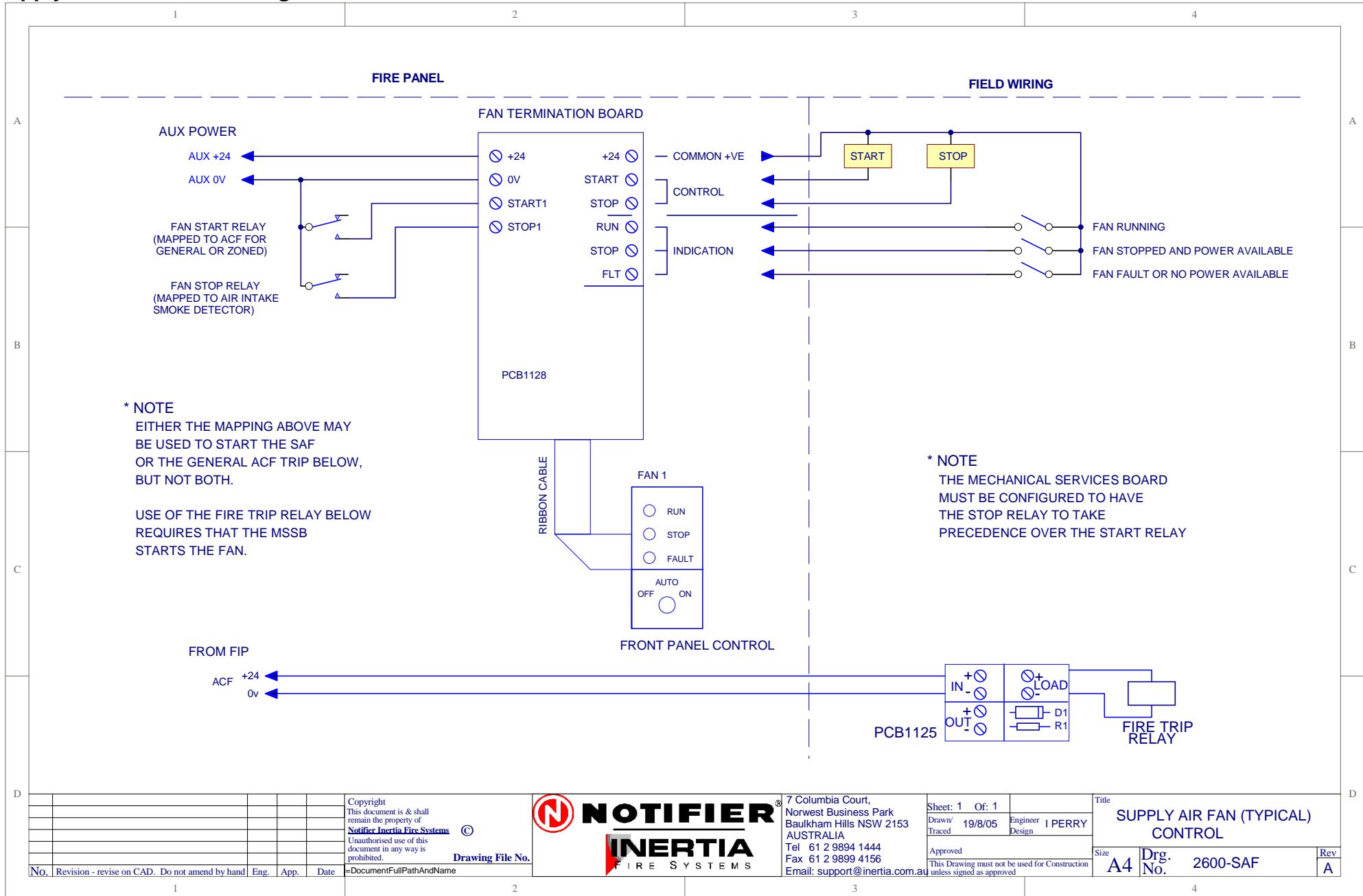

					Copyright This document is & shall remain the property of Notifier Inertia Fire Systems © Unauthorised use of this document in any way is prohibited.		7 Columbia Court, Norwest Business Park Baulkham Hills NSW 2153 AUSTRALIA Tel 61 2 9894 1444 Fax 61 2 9899 4156 Email: support@inertia.com.au		Sheet: 1 Of: 1 Drawn/ Traced: 19/8/05 Engineer Design: I PERRY	Title SUPPLY AIR FAN (TYPICAL) CONTROL	
No.	Revision - revise on CAD. Do not amend by hand	Eng.	App.	Date	DocumentFullPathAndName		Drawing File No.	Approved	This Drawing must not be used for Construction unless signed as approved	Size A4	Drg. No. 2600-SAF

Smoke Spill Fan Connection Diagram

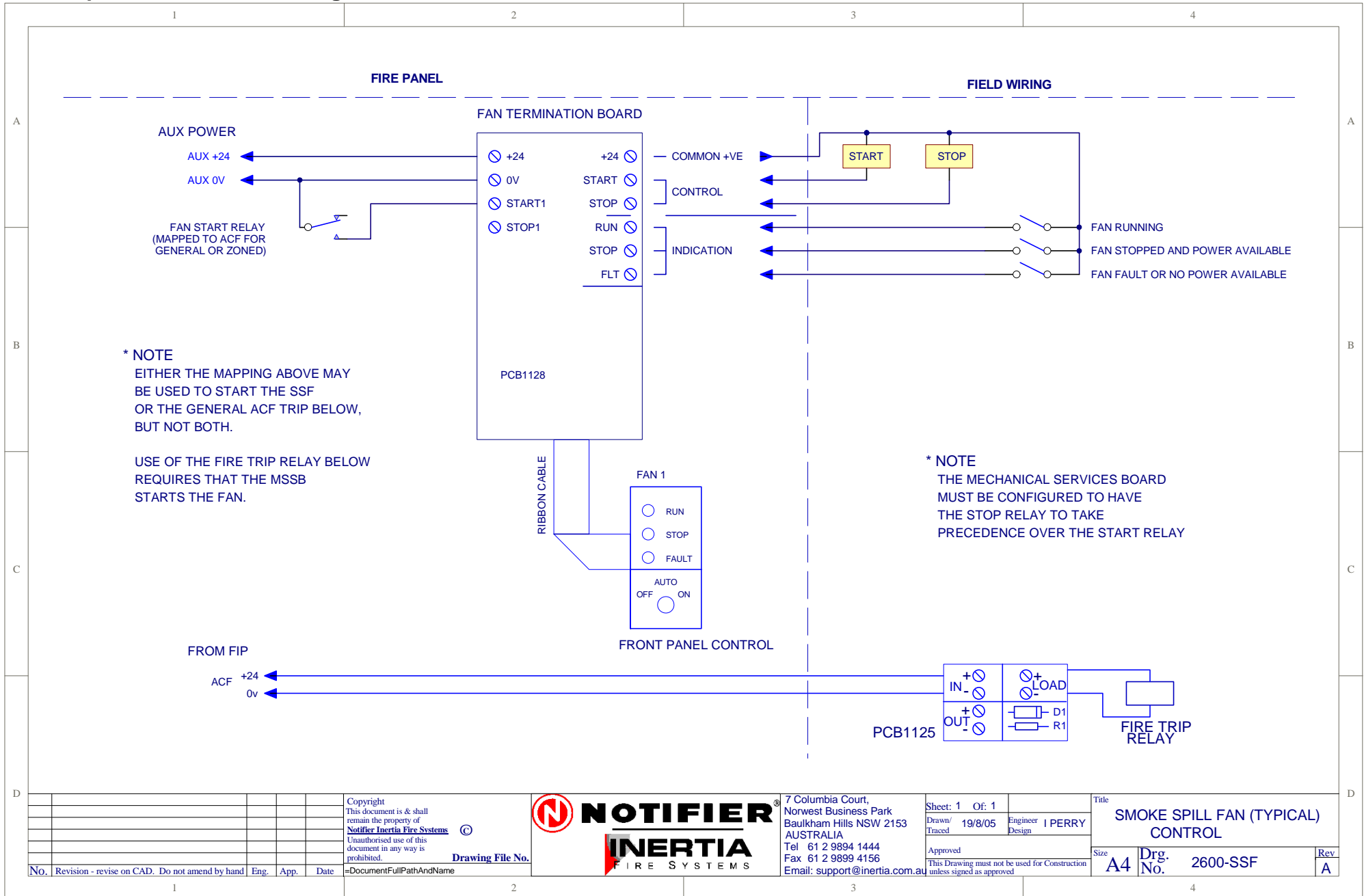

10W EVAC Connection Diagram

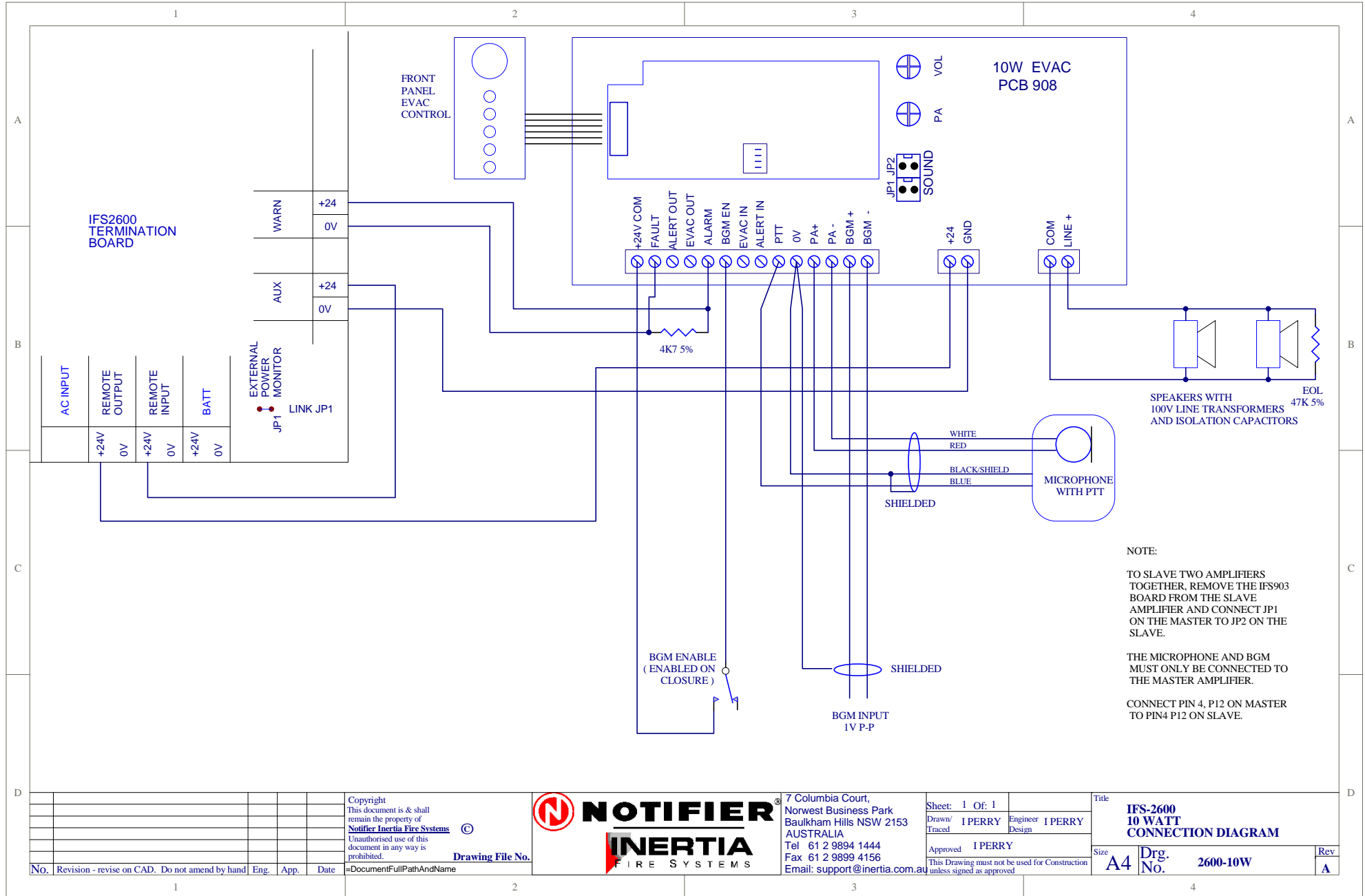

10W EVAC Slave Connection Diagram

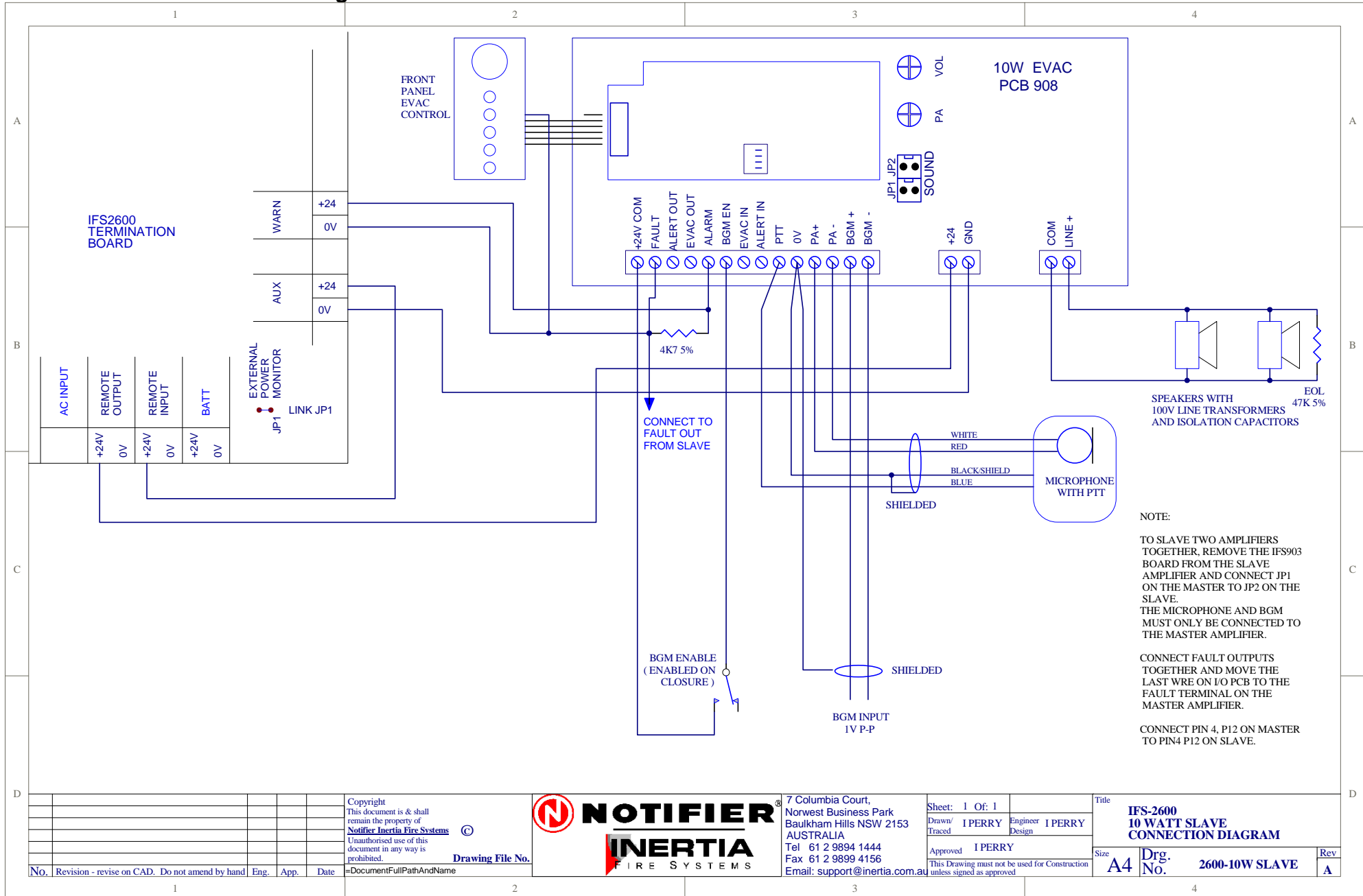

30W EVAC Connection Diagram

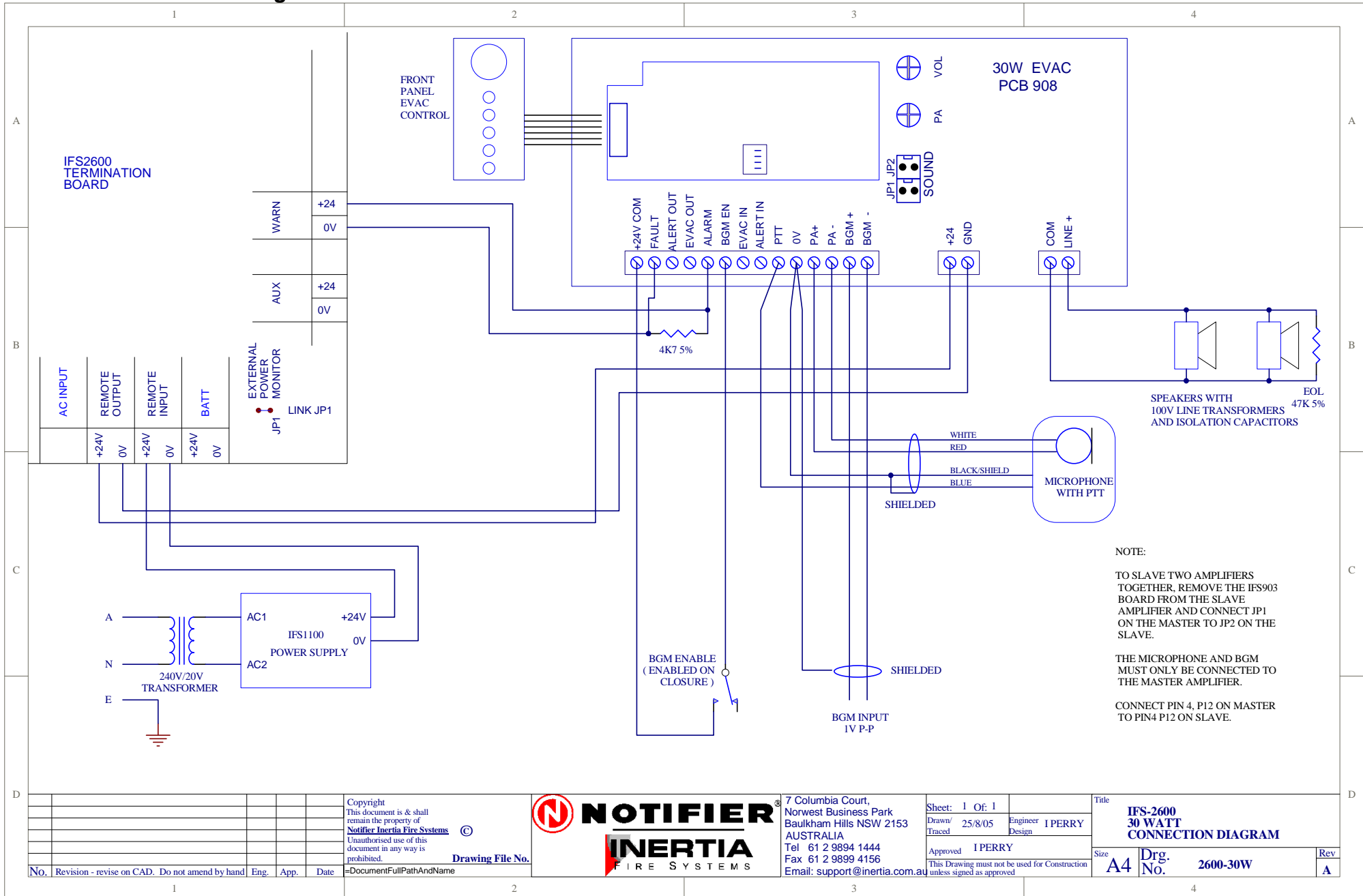

NOTE:
 TO SLAVE TWO AMPLIFIERS TOGETHER, REMOVE THE IFS903 BOARD FROM THE SLAVE AMPLIFIER AND CONNECT JP1 ON THE MASTER TO JP2 ON THE SLAVE.
 THE MICROPHONE AND BGM MUST ONLY BE CONNECTED TO THE MASTER AMPLIFIER.
 CONNECT PIN 4, P12 ON MASTER TO PIN4 P12 ON SLAVE.

No.	Revision - revise on CAD. Do not amend by hand	Eng.	App.	Date

Copyright
 This document is & shall remain the property of
Notifier Inertia Fire Systems
 Unauthorised use of this document in any way is prohibited.
 Drawing File No. _____
 =DocumentFullPathAndName



7 Columbia Court,
 Norwest Business Park
 Baukhams Hills NSW 2153
 AUSTRALIA
 Tel 61 2 9894 1444
 Fax 61 2 9899 4156
 Email: support@inertia.com.au

Sheet: 1 Of: 1
 Drawn/ Traced: 25/8/05
 Engineer/ Design: 1 PERRY
 Approved: 1 PERRY
 This Drawing must not be used for Construction unless signed as approved

Title: **IFS-2600 30 WATT CONNECTION DIAGRAM**
 Size: **A4**
 Drg. No.: **2600-30W**
 Rev: **A**

30W EVAC Slave Connection Diagram

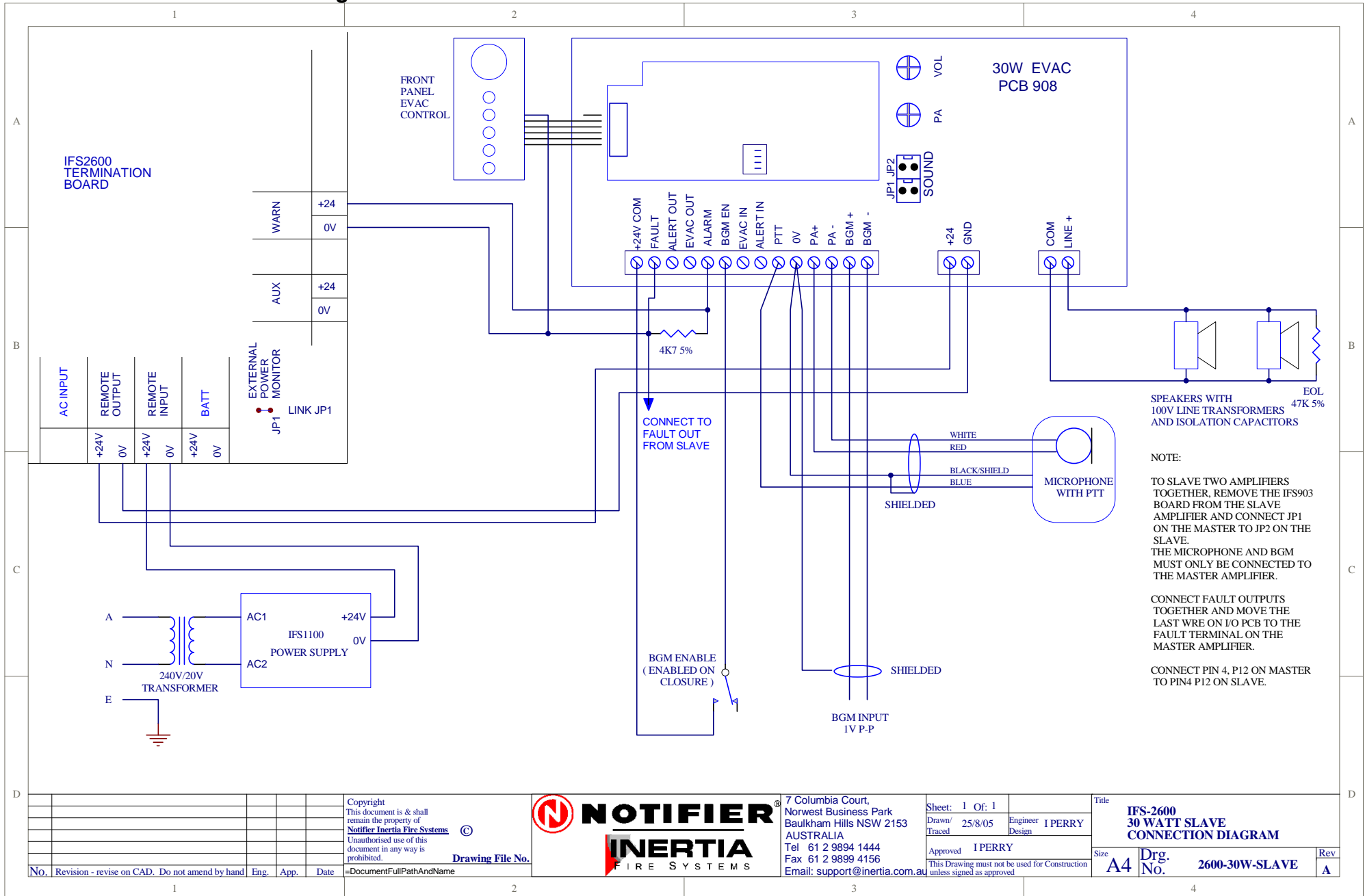

Copyright This document is & shall remain the property of Notifier Inertia Fire Systems © Unauthorized use of this document in any way is prohibited.						7 Columbia Court, Norwest Business Park Baulkham Hills NSW 2153 AUSTRALIA Tel 61 2 9894 1444 Fax 61 2 9899 4156 Email: support@inertia.com.au		Sheet: 1 Of: 1 Drawn/ Traced: 25/8/05 Engineer Design: I PERRY Approved: I PERRY	Title: IFS-2600 30 WATT SLAVE CONNECTION DIAGRAM
NO.	Revision - revise on CAD. Do not amend by hand	Eng.	App.	Date		Drawing File No. =DocumentFullPathAndName	Size: A4	Drg. No. 2600-30W-SLAVE	Rev A

50W EVAC Connection Diagram

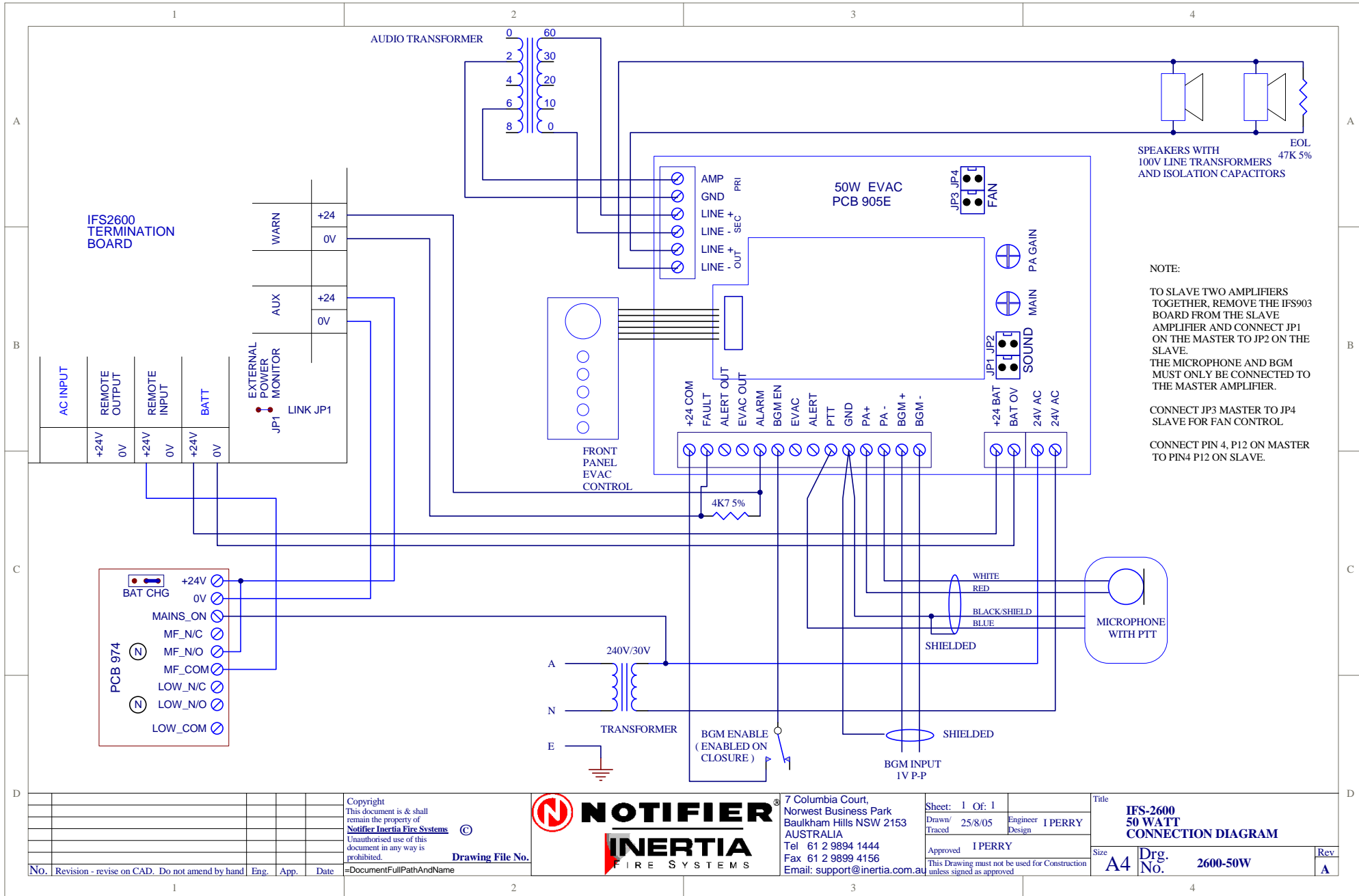

50W EVAC Slave Connection Diagram

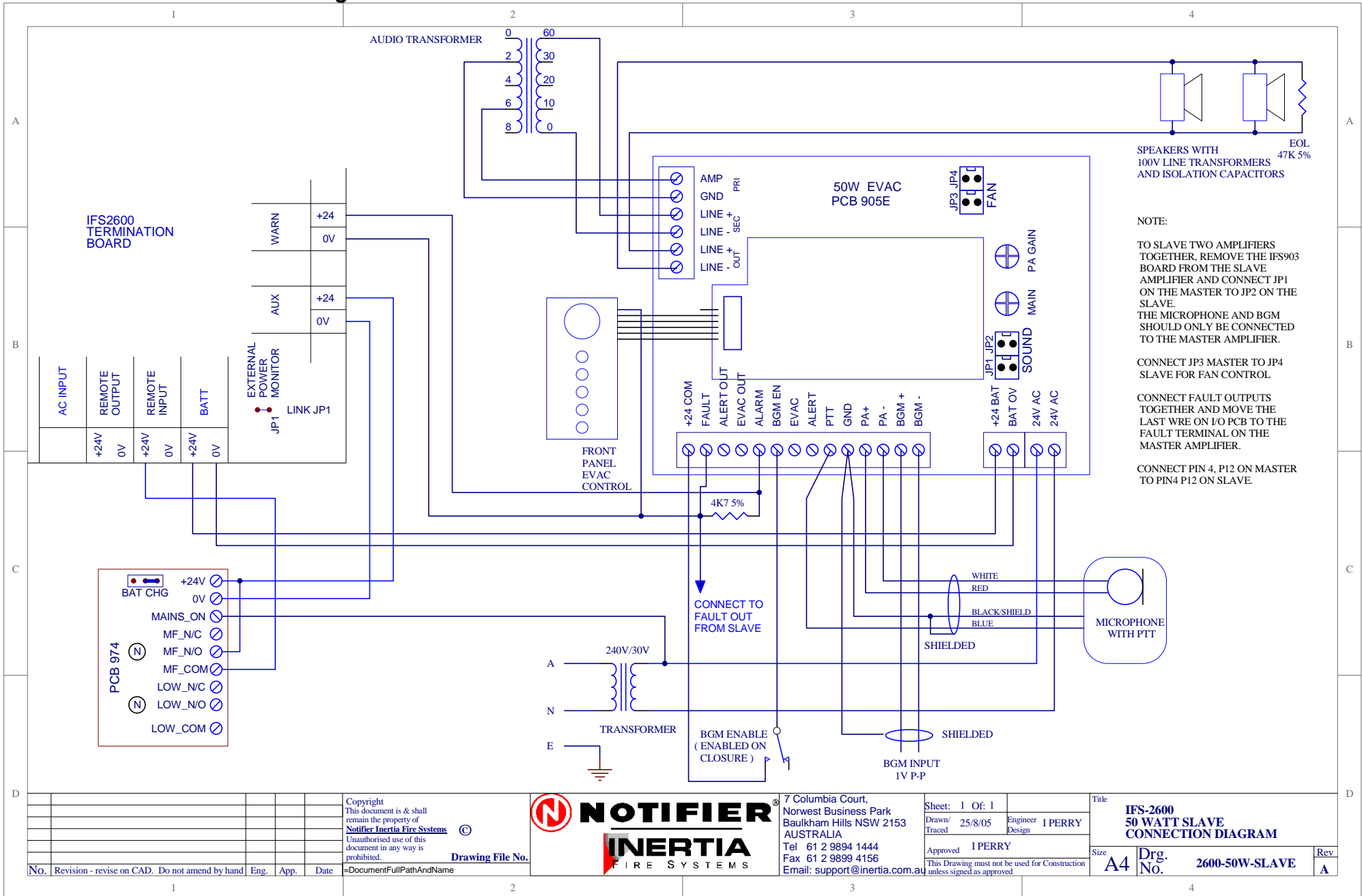

Notes

Notes



**New South Wales
(Head Office)**

7 Columbia Court
Baulkham Hills NSW 2153

ph +61 (0)2 9899-4155
fax +61 (0)2 9899-4156

Queensland

24 Potts Street
East Brisbane, QLD 4169

ph +61 (0)7 3391 5777
fax +61 (0)7 3391 5800

Victoria

32 Lambert Street
Richmond, VIC 3121

ph +61 (0)3 9421 5552
fax +61 (0)3 9421 5553

Western Australia

Unit 4, 283 Camboon Road
Malaga WA 6090

ph +61 (0)8 9270 6555
fax +61 (0)8 9270 6556

New Zealand

264 Mt Eden Road
Auckland

ph +64 (0)9 623 5275
fax +64 (0)9 623 5060